

4116-22-2223 Block Downconverter, 2.20 - 2.30 GHz, 2 Channel, Weather Resistant*

The 4116-22-2223 Block Downconverter, 2.20-2.30 GHz, 2 Channel, converts two 2.20-2.30 GHz RF channels to 1.200 - 1.300 GHz (non-inverted) with a common LO of 1.00 GHz. Front panel LEDs provide indication of DC Power, and PLL Alarm. The RF to L-band maximum gain is +35 ±2 dB, (+35 to +5 dB variable in 0.5 ±0.5 dB steps). Connectors are Type N female for RF IN and OUT, optional RF INPUT monitor, and SMA female for the external reference input and output. Gain and internal/external 10 MHz frequency select are controlled by the Ethernet M&C or via the Status/Control connector. In AUTO, the 10 MHz reference stays in external if the external level is in the +2 to +8 dBm range. Powered by a 100-240 ± 10% VAC power supply, in a 8" W X 6" H X 16" D Weather Resistant* enclosure.

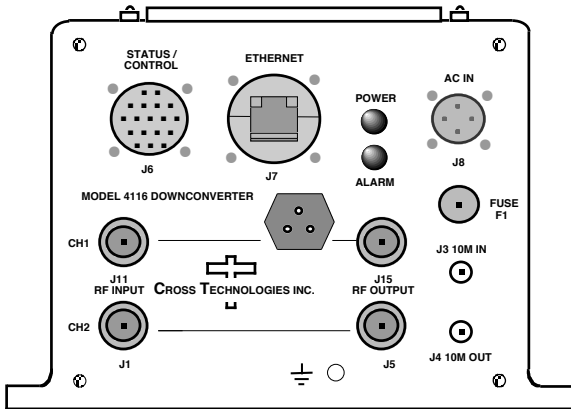

**4116-22-2223
Downconverter**

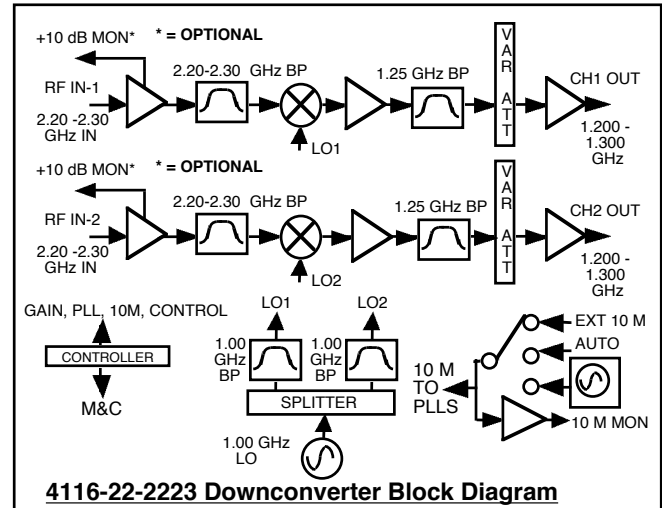

4116-22-2223 Downconverter Block Diagram

EQUIPMENT SPECIFICATIONS**

Input Characteristics (all channels)

Impedance/Return Loss 50Ω/14 dB
 Frequency **2.20 to 2.30 GHz**
 Noise Figure, Max. 15 dB at Fc, Gmax
 Input Level range -55 to -35 dBm, Fc

Output Characteristics (all channels)

Impedance/Return Loss 50 Ω /14 dB
 Frequency 1.200 - 1.300 GHz
 Output Level Range **-20 to 0 dBm, Fc, Gmax**
 Output 1 dB compr. +10 dBm, at Fc, Gmax

Channel Characteristics (all channels)

Gain at Fc +35 dB ±2 dB max., (+35 to +5 dB variable in 0.5 ±0.5 dB steps), Fc
 Image Rejection > 60 dB, min
 Spurious, Inband SIGNAL RELATED <-60 dBc in band; SIGNAL INDEP., <-60 dBm, (1.200 - 1.300 GHz, 0 dBm out) Gmax
 Spurious, Out of band <-50 dBm spurious, signal independent; 0.5-1.200 and 1.300- 2.5 GHz out, Gmax
 Intermodulation <-55 dBc for two carriers at Fc ± 2 MHz spacing, each at -10 dBm out, Gmax
 Frequency Response ±1.5 dB, 1.200 - 1.300 GHz out; ±0.5 dB, 40 MHz BW, Gmax
 Frequency Sense **non-Inverted**

LO Characteristics (all channels)

LO Frequency **1.00 GHz, Fixed (non-Inverting)**
 Frequency Accuracy ± 0.05 ppm max over temp internal reference; ext. ref. input
 10 MHz level In/Mon Input=+2 to +8 dBm in; Monitor Output = Input Level ± 1.0 dB, 50 ohms

Phase Noise @ F (Hz) >	100	1K	10K	100K	1M
dBc/Hz	70	80	85	95	110

***Weather Resistant** enclosures are designed to be water resistant for installation in an outdoor enclosure /antenna hut OR mounted outdoors on an antenna assembly at their specified temperature ranges. They are designed to be located "out in the elements" (water, sleet, snow, etc.) but they are *not* designed to be "submerged under" water.

Options
W21 -30° to +60°C Operation
W74M+0 0dB Input Monitor
W74M+10 +10dB Input Monitor
VO15 +15 ±0.5 VDC, 1.50 A
VO15-2 +15 ±0.5 VDC, 2.00 A

Controls, Indicators

Gain, 10M Freq. Gain and internal/external 10 MHz frequency select via Ethernet (w/SNMP) M&C or Status/Control Connector
 Power; PLL Alarm Green LED ; Red LED, External contact closure

Other

Connectors*	Connector P/N	Mating Connector P/N	Additional Connector Specifications*			M&C Interface
Status/Control Connector	MS3112E14-18S	MS3116F14-18P	RF In, Out	RF MON	10 MHz In/Out	RS232/422/485; Ethernet: Web Browser, SNMP & TCP/IP STD.
AC Input Connector**	CL1M1102	CL1F1101	Type N (F) 50 Ω	Type N (F) 50 Ω	SMA (Female) 50 Ω	
Ethernet Connector / RJ45	RJF21B	RJF6G				

* All cable connectors are Weather resistant. ** AC mating connector PROVIDED preassembled onto standard NEMA 5-15 U.S. power cord.

Size 8"W X 6"H X 16"D Weather Resistant* Enclosure
 Power 100-240 ±10% VAC, 47 - 63 Hz, 25 watts maximum.

**+0 to +50 degrees C; Specifications subject to change without notice