

Instruction Manual

Model 2116-117 Block Downconverter

May 2013, Rev. D



Data, drawings, and other material contained herein are proprietary to Cross Technologies, Inc., but may be reproduced or duplicated without the prior permission of Cross Technologies, Inc. for purposes of operating the equipment.

When ordering parts from Cross Technologies, Inc., be sure to include the equipment model number, equipment serial number, and a description of the part.



6170 Shiloh Road
Alpharetta, Georgia 30005

(770) 886-8005
FAX (770) 886-7964
Toll Free 888-900-5588

WEB www.crosstechnologies.com
E-MAIL info@crosstechnologies.com

INSTRUCTION MANUAL

MODEL 2116-117 Block Downconverter

<u>TABLE OF CONTENTS</u>	<u>PAGE</u>
Warranty	2
1.0 General	3
1.1 Equipment Description	3
1.2 Technical Characteristics	4
2.0 Installation	5
2.1 Mechanical	5
2.2 Rear Inputs and Outputs	6
2.3 Front Panel Indicators	6
2.4 Operation	7
3.0 Environmental Use Information	8

WARRANTY - The following warranty applies to all Cross Technologies, Inc. products.

All Cross Technologies, Inc. products are warranted against defective materials and workmanship for a period of one year after shipment to customer. Cross Technologies, Inc.'s obligation under this warranty is limited to repairing or, at Cross Technologies, Inc.'s option, replacing parts, subassemblies, or entire assemblies. Cross Technologies, Inc. shall not be liable for any special, indirect, or consequential damages. This warranty does not cover parts or equipment which have been subject to misuse, negligence, or accident by the customer during use. All shipping costs for warranty repairs will be prepaid by the customer. There are not other warranties, express or implied, except as stated herein.



6170 Shiloh Road
Alpharetta, Georgia 30005

(770) 886-8005
FAX (770) 886-7964
Toll Free 888-900-5588

WEB www.crosstechnologies.com
E-MAIL info@crosstechnologies.com

MODEL 2116-117 Block Downconverter

1.0 General

1.1 Equipment Description

The 2116-117 Downconverter converts 11.7 - 12.75 GHz to 0.95 - 2.00 GHz with a local oscillator at 10.75 GHz. Front panel LEDs provide indication of DC Power, External 10 MHz, and PLL Alarm. The gain is +35 dB (+25 dB for Option W25). Connectors are SMA female for the RF and BNC female for the L-Band and external reference input and reference output. A three-way switch controls which 10 MHz reference is being used. In the INT position, the internal reference is used, in the EXT position, the external reference is used, and in the AUTO position, the internal reference is used unless a +3 dBm \pm 3 dB, 10MHz reference signal is connected to the external reference input. The 2116 is powered by a 100-240 \pm 10% VAC power supply, and mounted in a 1 3/4" X 19" X 14" rack mount chassis.

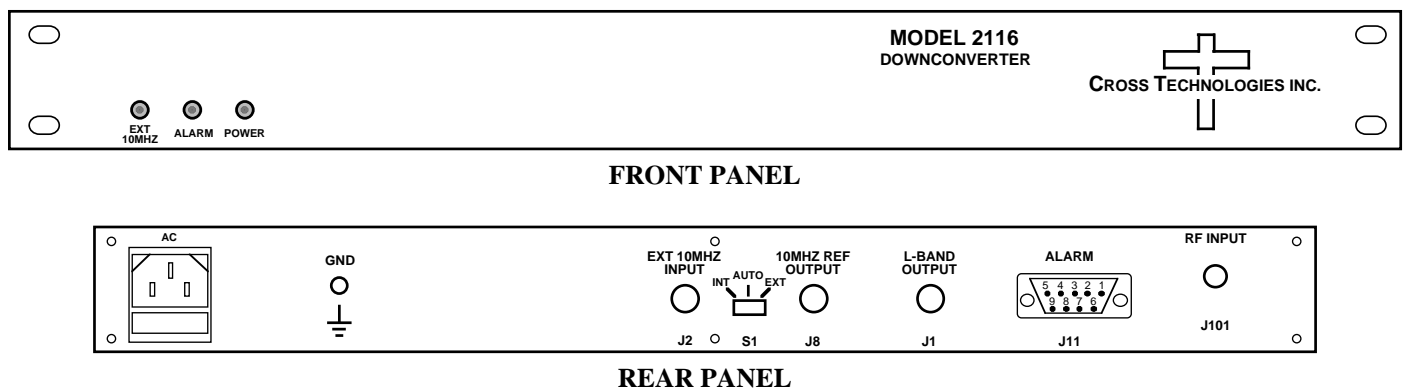

FIGURE 1.1 Model 2116-117 Front and Rear Panels

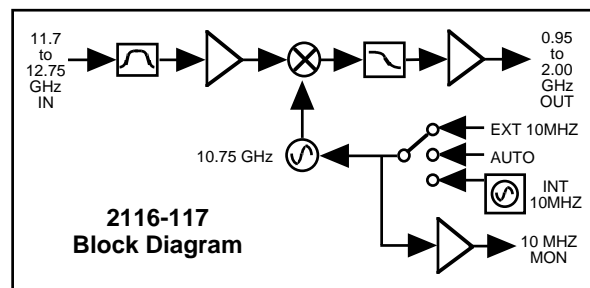

FIGURE 1.2 Model 2116-117 Downconverter Block Diagram

1.2 Technical Characteristics

TABLE 1.0 2116-117 Downconverter Specifications*

Input Characteristics

Impedance/Return Loss	50Ω /14 dB (see TABLE 2.2 for connector options)
Frequency	11.7 to 12.75 GHz
Noise Figure, max.	15 dB, max gain
Input Level	-55 to -35 dBm (-45 to -25 dBm; OPTION W25)
Input 1dB Compression	25 dBm (-15 dBm; OPTION W25)

Output Characteristics

Impedance/Return Loss	50Ω /14 dB (see TABLE 2.2 for connector options)
Frequency	0.95 to 2.0 GHz
Output Level Range	-20 to 0 dBm
Output 1dB Compression	+10 dBm

Channel Characteristics

Gain	+35 dB ± 2 dB (+25 dB +2 dB; OPTION W25)
Image Rejection	>60 dB, min.
Spurious, In Band	SIGNAL RELATED <-60 dBC in band, 0 dBm out SIGNAL INDEPENDENT, <-60 dBm
Spurious, Out of Band	<-50 dBm
Intermodulation	<-55 dBC for two carriers each at -10 dBm out
Frequency Response	±1.5 dB, 0.95 to 2.00 GHz out; ± 0.5 dB, 40 MHz BW
Frequency Sense	Non-inverting

LO Characteristics

LO Frequency	10.75 GHz
Frequency Accuracy	± 0.01 ppm max over temp internal reference; ext. ref. input
10 MHz In/Out Level	+3 dBm ± 3 dB

Phase Noise @ Freq	100 Hz	1kHz	10kHz	100kHz	1MHz
dBC/Hz	-70	-80	-85	-95	-110

Controls, Indicators

INT/AUTO/EXT Switch	Selects internal or external 10 MHz (rear panel DP3T switch)
Ext 10 MHz	Yellow LED, Indicates Ext 10 MHz reference selected
PLL Alarm	Red LED, External contact closure
Power	Green LED

Other

RF Connector	SMA (female) standard (see TABLE 2.2 for other options)
IF Connector	BNC (female) 50Ω standard (see TABLE 2.2 for other options)
10 MHz Connectors	BNC (female) 75Ω connector; Works with 50Ω or 75Ω.
Connector, Alarm	DB9, female - NO or NC contact closure on Alarm
Size	19 inch, 1RU standard chassis 1.75"high X 14.0" deep
Power	100-240 ±10% VAC, 47-63 Hz, 25 watts max

Options

Option W25	25dB Gain (see above specs relating to this option)
Connector options	See TABLE 2.2

*+10°C to +40°C; Specifications subject to change without notice.

2.0 Installation

2.1 Mechanical

The 2116-117 consists of a PCB and an RF assembly housed in a 1 RU (1 3/4 inch high) by 12 inch deep chassis. A switching, ± 12 , +24, +5 VDC power supply provides power for the assemblies. The 2116-117 can be secured to a rack using the 4 holes on the front panel. Figure 2.0 shows how the 2116-117 is assembled.

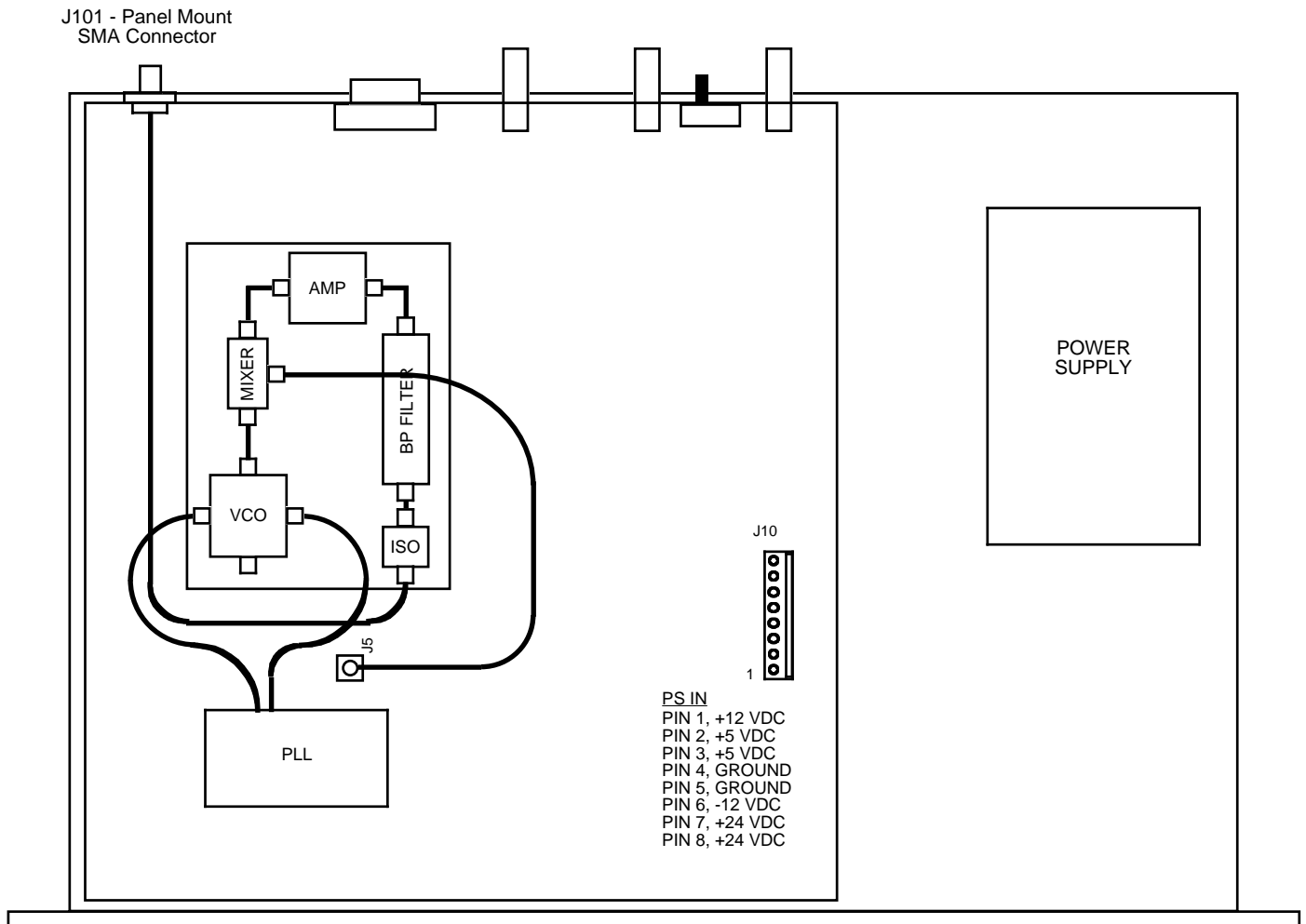

FIGURE 2.0 2116-117 Mechanical Assembly

2.2 Rear Panel Input/Output Signals

Figure 2.1 shows the input and output connectors on the rear panel.

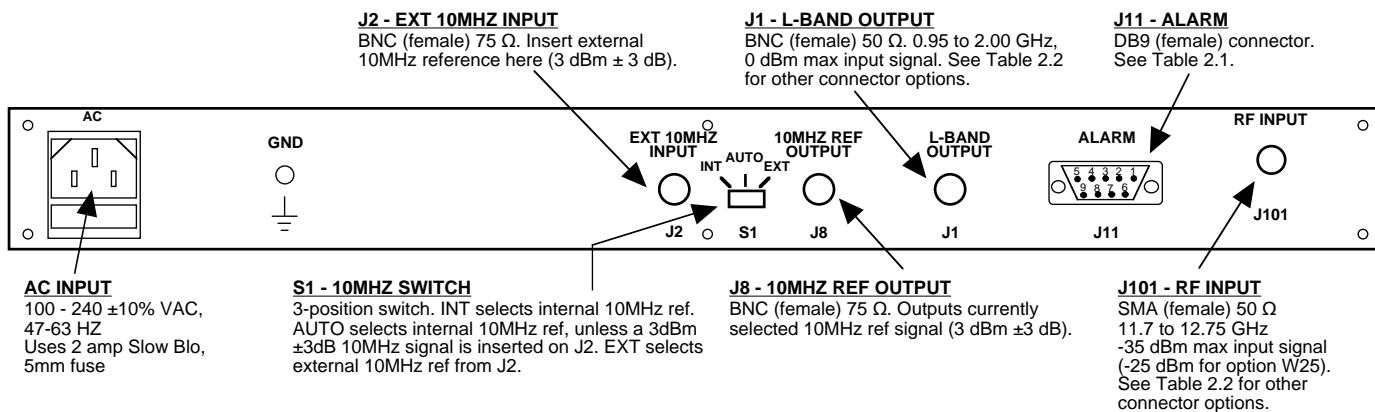

FIGURE 2.1 2116-117 Rear Panel I/O's

Pin	Function
1	Not Used
2	Not Used
3	Not Used
4	Not Used
5	GND
6	Alarm Relay: Common
7	Alarm Relay: Normally Open
8	Not Used
9	Alarm Relay: Normally Closed

Option	RF	L-Band
STD	SMA, 50Ω	BNC, 50Ω
M	Type N, 50Ω	BNC, 50Ω
N	Type N, 50Ω	BNC, 75Ω
NF	Type N, 50Ω	Type F, 75Ω
NN	Type N, 50Ω	Type N, 50Ω
S7	SMA, 50Ω	BNC, 75Ω
SF	SMA, 50Ω	Type F, 75Ω
SN	SMA, 50Ω	Type N, 50Ω
SS	SMA, 50Ω	SMA, 50Ω

2.3 Front Panel Indicators

Figure 2.2 shows the front panel indicators.

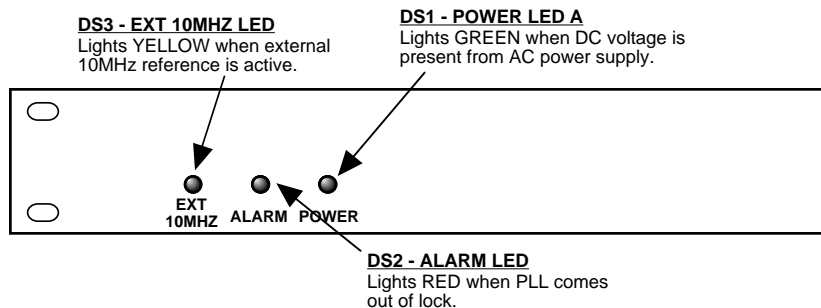

FIGURE 2.2 2116-117 Front Panel Controls and Indicators

2.4 Installation / Operation

2.4.1 Installing and Operating the 2116-117 Downconverter

1. Connect a -55 dBm to -35 dBm signal (-45 dBm to -25 dBm for Option W25) for to RF INPUT, J101 (Figure 2.1).
2. Connect the L-BAND OUTPUT, J1, to the external equipment.
3. Connect 100-240 \pm 10% VAC, 47 - 63 Hz to AC connector on the back panel.
4. Be sure DS1 (green, DC Power) is on and DS2 (red, Alarm) is off (Figure 2.2).
5. Select either INT (for internal 10MHz ref), AUTO (for internal 10MHz ref UNLESS an external 10MHz, 3 dBm signal is connected to J2), or EXT (for external 10MHz, 3 dBm ref that is inserted at J2) on rear panel switch S1 (Figure 2.1).
6. If EXT is selected or AUTO is selected and there is a 10MHz, 3 dBm signal at J2, check that DS3 (yellow, Ext 10MHZ) is on (Figure 2.2).
7. Check that a 10MHz, 3 dBm \pm 3 dB signal is present at the 10MHZ REF OUTPUT (J8) (Figure 2.1).
8. AC Fuse - The fuse is a 5 mm X 20 mm, 2 amp slow blow (Type T) and is inserted in the far slot in the drawer below the AC input as shown in Figure 2.3. There is a spare fuse in the near slot. If a fuse continues to open, the power supply is most likely defective.

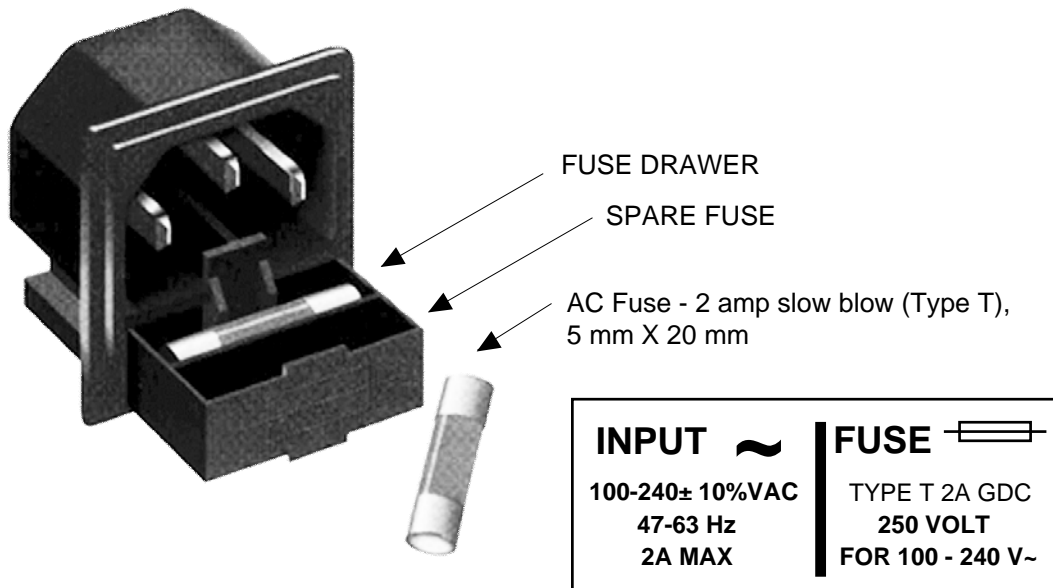

FIGURE 2.3 Fuse Location and Spare Fuse

3.0 Environmental Use Information

- A. **Rack-Mounting** - To mount this equipment in a rack, please refer to the installation instructions located in the user manual furnished by the manufacturer of your equipment rack.
- B. **Mechanical Loading** - Mounting of equipment in a rack should be such that a hazardous condition does not exist due to uneven weight distribution.
- C. **Elevated Operating Ambient Temperature** - If installed in a closed or multi-unit rack assembly, the operating ambient temperature of the rack may be greater than room ambient temperature. Therefore, consideration should be given to Tmra.
- D. **Reduced Air Flow** - Installation of the equipment in a rack should be such that the amount of air flow required for safe operation of the equipment is not compromised. Additional space between units may be required.
- E. **Circuit Overloading** - Consideration should be given to the connection of the equipment to the supply circuit and the effect that overloading of circuits could have on over current protection and supply wiring. Appropriate consideration of equipment name plate rating should be used, when addressing this concern.
- F. **Reliable Earthing** - Reliable earthing of rack-mounted equipment should be maintained. Particular attention should be given to supply connections other than direct connection to the Branch (use of power strips).
- G. **Top Cover** - There are no serviceable parts inside the product so, the Top Cover should not be removed. If the Top Cover is removed the ground strap and associated screw **MUST BE REINSTALLED** prior to Top Cover screw replacement. **FAILURE TO DO** this may cause **INGRESS** and/or **EGRESS** emission problems.



6170 Shiloh Road
Alpharetta, Georgia 30005

(770) 886-8005
FAX (770) 886-7964
Toll Free 888-900-5588

WEB www.crosstechnologies.com
E-MAIL info@crosstechnologies.com

PRINTED IN USA