

Instruction Manual

Model 2099-218

10MHz Source/Inserter

Redundant 18V

January 2011, Rev. A

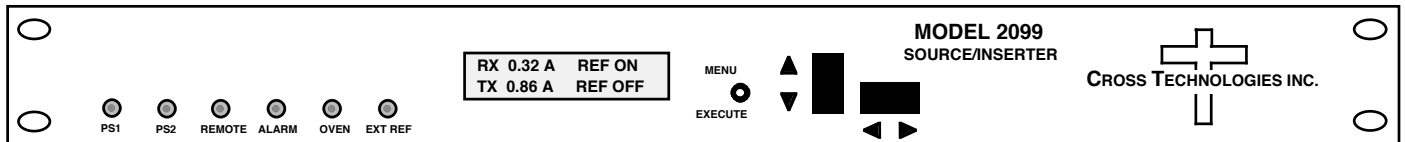

Data, drawings, and other material contained herein are proprietary to Cross Technologies, Inc., but may be reproduced or duplicated without the prior permission of Cross Technologies, Inc. for purposes of operating the equipment.

When ordering parts from Cross Technologies, Inc., be sure to include the equipment model number, equipment serial number, and a description of the part.

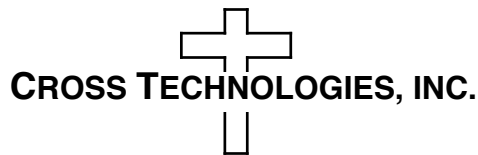

6170 Shiloh Road
Alpharetta, Georgia 30005

(770) 886-8005
FAX (770) 886-7964
Toll Free 888-900-5588

WEB www.crosstechnologies.com
E-MAIL info@crosstechnologies.com

INSTRUCTION MANUAL

MODEL 2099-218 10MHz Source/Insertter

<u>TABLE OF CONTENTS</u>	<u>PAGE</u>
Warranty	2
1.0 General	3
1.1 Equipment Description	3
1.2 Technical Characteristics	4
1.3 Environmental Use Information	5
1.4 Monitors & Controls	6
2.0 Installation	9
2.1 Mechanical	b
2.2 Rear Panel Outputs	10
2.3 Front Panel Indicators	11
2.4 Operation	12
2.5 Menu Settings	13

WARRANTY - The following warranty applies to all Cross Technologies, Inc. products.

All Cross Technologies, Inc. products are warranted against defective materials and workmanship for a period of one year after shipment to customer. Cross Technologies, Inc.'s obligation under this warranty is limited to repairing or, at Cross Technologies, Inc.'s option, replacing parts, subassemblies, or entire assemblies. Cross Technologies, Inc. shall not be liable for any special, indirect, or consequential damages. This warranty does not cover parts or equipment which have been subject to misuse, negligence, or accident by the customer during use. All shipping costs for warranty repairs will be prepaid by the customer. There are not other warranties, express or implied, except as stated herein.



6170 Shiloh Road
Alpharetta, Georgia 30005

(770) 886-8005
FAX (770) 886-7964
Toll Free 888-900-5588

WEB www.crosstechnologies.com
E-MAIL info@crosstechnologies.com

MODEL 2099-218 10MHz Source/Inserter

1.0 General

1.1 Equipment Description

The 2099-218 10 MHz Source/Inserter is a 10 MHz, ± 0.01 ppm oven controlled crystal oscillator (OCXO) with circuitry to insert the 10 MHz signal and DC voltage on L-band lines for an LNB and SSPB. Multi-function push button switches select **Internal**, **Auto (Auto switches to internal when external source < -2 dBm)**, or **External** 10MHz and insertion of 10 MHz on the L-band lines. LEDs indicate DC power (green), alarm (red), remote operation (yellow), and OCXO oven warm-up (yellow). Remote control allows remote configuration of front panel commands and monitoring LNB and SSPB current. Parameter selection and LNB and SSPB current appear on the LCD display. Connectors are BNC female for RF and 10 MHz external input and output signals. LNB or SSPB +18 VDC can be inserted on the RF lines by installing the fuses. **Redundant** AC power is 100-240 \pm 10% VAC, 47-63 Hz. The unit is 1 RU, 16" deep.

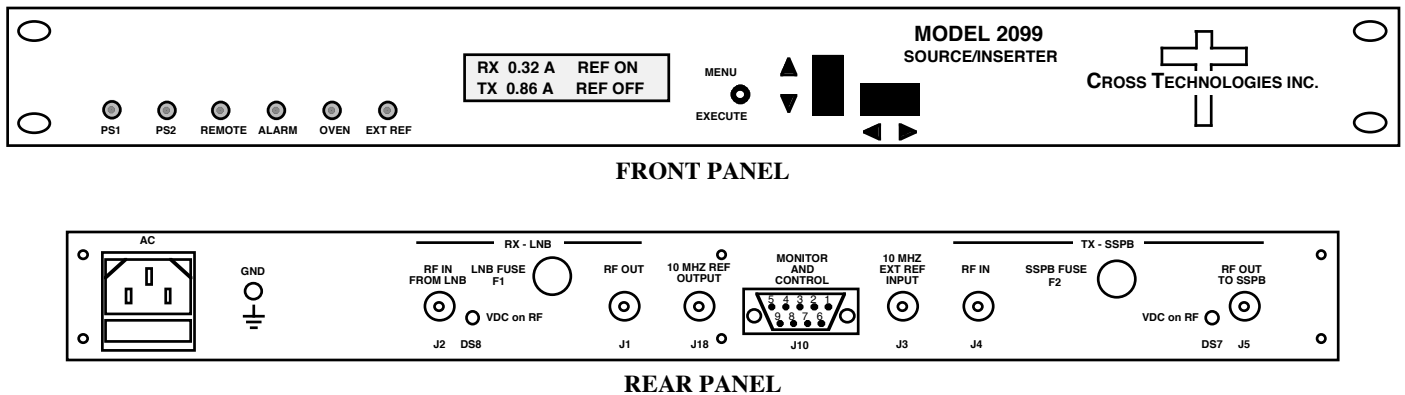

FIGURE 1.1 Model 2099-218 Front and Rear Panels

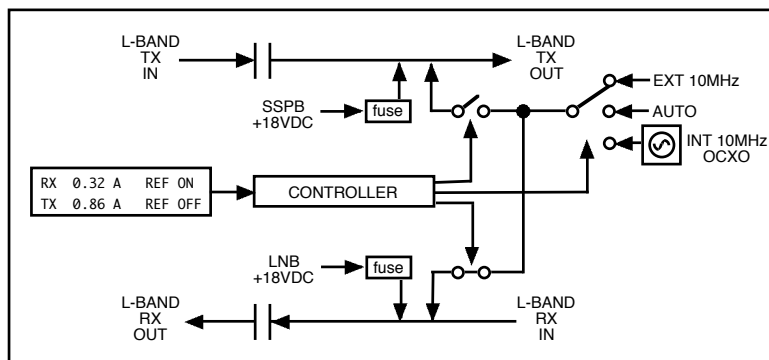

FIGURE 1.2 Model 2099-218 10MHz Source/Inserter Block Diagram

1.2 Technical Characteristics

TABLE 1.0 2099-218 MHz Source/Inserter Specifications*

-----10 MHz REFERENCE-----

Output Characteristics (on L-band RF)

Level	+2 dBm ± 2 dB
Harmonics	<-30 dBC, <-40 dBC typ
Level to non-insert end	<-20 dBm, <-30 dBm typ

Input/Output Characteristics (on BNC connectors)

Impedance, Return Loss	50Ω/75Ω, 16 dB
Level	+3 dBm ± 3 dB
Harmonics (Output)	<-30 dBC, <-40 dBC typ
(In Auto, Auto switches to internal when external source < -2 dBm)	

Internal Oscillator

Stability	± 0.01 ppm max over temp
Aging, per day	± 0.001 ppm
Aging, per year	± 0.1 ppm
Warm-up, 4 minutes	± 0.1 ppm
Warm-up, 1 hour	± 0.01 ppm
Tuning Adjust	± 0.5 ppm

Phase Noise @ Freq	10Hz	100Hz	1kHz	10kHz
dBC/Hz	-110	-140	-149	-149

LNB, SSPB DC Power Characteristics

Voltage/Current	LNB +18 VDC, ±10%, 0.5 A. max.; SSPB +18 VDC, ±10%, 1.0 A. max. Call for other voltages
Load Regulation	±5 %

-----CHASSIS/OTHER-----

Controls & Indicators

INT/AUTO/EXT 10M Sel.	direct readout LCD; manual or remote selection
10 MHz Insert Select	direct readout LCD; manual or remote selection
LNB, SSPB Current	direct readout LCD; remote monitor
Power, Alarm, Remote	Green LED, Red LED, Yellow LED
Oven Warm-up, Ext Ref	Yellow LED, Yellow LED
Remote	RS232C, 9600 baud (RS485, option Q)

Available Options

-Q	RS485/RS422 Remote Interface
-W8	Ethernet Remote Interface
-W18	Ethernet with SNMP Remote Interface
Connectors/Impedance	
-D	50Ω BNC (RF)

Other

RF Connectors	F-Type, 75Ω (female); 50Ω BNC (RF), option D
10 MHz Connectors	BNC, 75Ω/50Ω (female)
Alarm/Remote Connector	DB9 (female) - NO or NC closure on Alarm
Size	19 inch, 1RU standard chassis • 1.75”H x 16.0”D
Power	100-240 ±10% VAC, 47-63 Hz, 90 Watts max.

*+10°C to +40°C; Specifications subject to change without notice.

-----RX & TX L-BAND INSERTION-----

Input/Output Characteristics

Frequency	950 - 2150 MHz
Impedance	75Ω
Return Loss	>12 dB, 0.95 - 1.5 GHz >10 dB, 1.5 - 2.15 GHz
Insertion Loss	< 1 dB, 0.95 - 1.5 GHz < 2 dB, 1.5 - 2.15 GHz
Frequency Response	±1.0 dB, 950 - 2150 MHz; ± 0.5 dB, 36MHz BW

1.3 Environmental Use Information

- A. **Rack-Mounting** - To mount this equipment in a rack, please refer to the installation instructions located in the user manual furnished by the manufacturer of your equipment rack.
- B. **Mechanical Loading** - Mounting of equipment in a rack should be such that a hazardous condition does not exist due to uneven weight distribution.
- C. **Elevated Operating Ambient Temperature** - If installed in a closed or multi-unit rack assembly, the operating ambient temperature of the rack may be greater than room ambient temperature. Therefore, consideration should be given to T_{mra} .
- D. **Reduced Air Flow** - Installation of the equipment in a rack should be such that the amount of air flow required for safe operation of the equipment is not compromised. Additional space between unit may be required.
- E. **Circuit Overloading** - Consideration should be given to the connection of the equipment to the supply circuit and the effect that overloading of circuits could have on over current protection and supply wiring. Appropriate consideration of equipment name plate rating should be used when addressing this concern.
- F. **Reliable Earthing** - Reliable earthing of rack-mounted equipment should be maintained. Particular attention should be given to supply connections other than direct connection to the Branch (use of power strips).
- G. **Top Cover** - There are no serviceable parts inside the product so, the Top Cover should not be removed. If the Top Cover is removed the ground strap and associated screw **MUST BE REINSTALLED** prior to Top Cover screw replacement. **FAILURE TO DO** this may cause **INGRESS** and/or **EGRESS** emission problems.

1.4 Monitor and Control Interface

A) Remote serial interface

Protocol: RS-232C, 9600 baud rate, no parity, 8 data bits, 1 start bit, and 1 stop bit.
(RS-232C, RS-422, or **RS-485 - option -Q**)

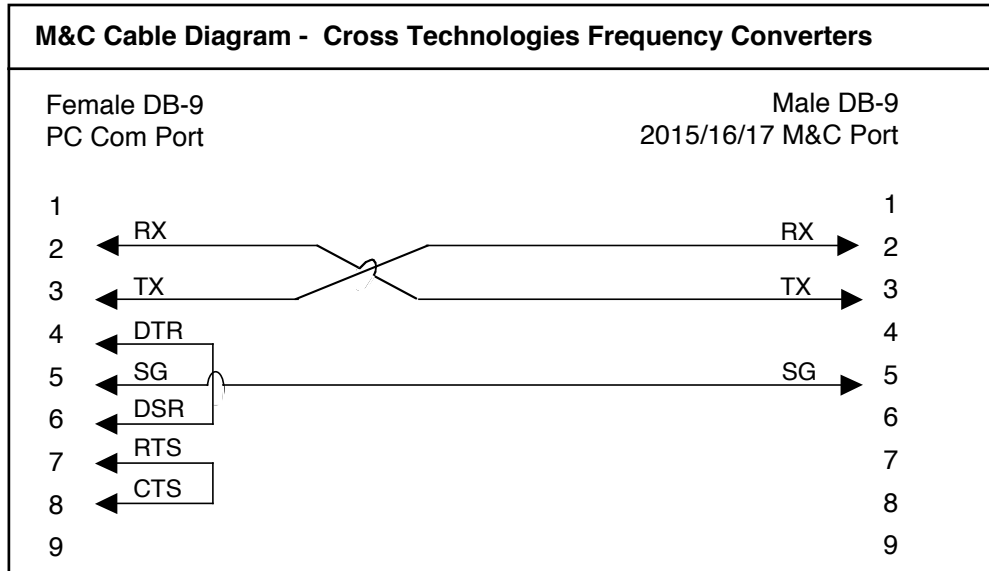

Connector: Rear panel, DB-9 female.

J10 Pinouts (RS-232C/422/485)	
Pin	Function
1	Rx-
2	Rx+ (RS-232C)
3	Tx+ (RS-232C)
4	Tx-
5	GND
6	Alarm Relay: Common
7	Alarm Relay: Normally Open
8	Not Used
9	Alarm Relay: Normally Closed

B) Status Requests

Table 1.1 lists the status requests for the 2099-218 and briefly describes them.

* PLEASE NOTE: The two character {aa}(00-31) prefix, in the table below, should be used ONLY when RS-485, (OPTION-Q), is selected.

Table 1.1 2099-218 Status Requests		
Command	Syntax*	Description
Command Status	{aaS2}	Returns {aaS2bcdefghi} where:
		• b = 0 (Internal), 1 (External), or 2 (Auto) Reference
		• c = 1 - 10MHz inserted on upconverter RF (J5)
		• d = 1 - 10MHz inserted on downconverter RF (J2)
		• e = 1 - FAULT condition in Auto Reference mode **
		• f = 1 - Oven Alarm
		• g = 1 - Summary Alarm
		• h = 1 - Power Supply 1 Alarm
		• i = 1 - Power Supply 2 Alarm
LNB Current	{aaS3}	Returns {aaS3bb} where:
		• bb = LNB current, range 00 to 50 (0 to 500 ma)
SSPB Current	{aaS4}	Returns {aaS4bbb} where:
		• bbb = SSPB current, range 000 to 100 (0 to 1000 ma)
Reference Offset	{aaS8}	Returns {aaS8bbbb} where:
		• bbbb = Reference Offset, range 500 to -500

** FAULT! occurs when in Auto Reference mode and the external reference fails.

C) Commands

Table 1.2 lists the commands for the 2099-218 and briefly describes them. After a command is sent the 2099-218 sends a return ">" indicating the command has been received and executed.

General Command Format - The general command format is {aaCND...}, where:

- { = start byte
- aa = Address (**RS-485 only**)
- C = 1 character, either C (command) or S (status)
- N = 1 character command or status request
- D = 1 character or more of data (depends on command)
- } = stop byte

* PLEASE NOTE: The two character {aa}(00-31) prefix, in the table below, should be used ONLY when RS-485, (OPTION-Q), is selected.

Table 1.2 2099-218 Commands		
Command	Syntax*	Description
External 10MHz	{aaCEx}	where x =: <ul style="list-style-type: none"> • 0 for Internal 10MHz Reference signal • 1 for External 10MHz Reference signal • 2 for Auto 10MHz Reference
Insert 10MHz on TX RF	{aaC5x}	where x =: <ul style="list-style-type: none"> • 0 to disable 10MHz transmitter insertion on RF (J5) • 1 to enable 10MHz transmitter insertion on RF (J5)
Insert 10MHz on RX RF	{aaC6x}	where x =: <ul style="list-style-type: none"> • 0 to disable 10MHz receiver insertion on RF (J2) • 1 to enable 10MHz receiver insertion on RF (J2)
Frequency Offset Adjust	{aaC8xxxx}	where xxxx =: <ul style="list-style-type: none"> • xxxx = 3 or 4 characters • Range: 2000 to -2000
Enable Remote	#	Just # sign
Disable Remote	{aaCRO}	{CR and zero}

2.0 Installation

2.1 Mechanical - The 2099-218 consists of one RF PCB housed in a 1 RU (1 3/4 inch high) by 16 inch deep chassis. A switching, ± 12 , +24, +5 VDC power supply provides power for the assemblies. A separate +24VDC power supply (+48VDC, **option V48**) provides power for the SSPB. The 2099-218 can be secured to a rack using the 4 holes on the front panel. Figure 2.0 shows how the 2099-218 is assembled.

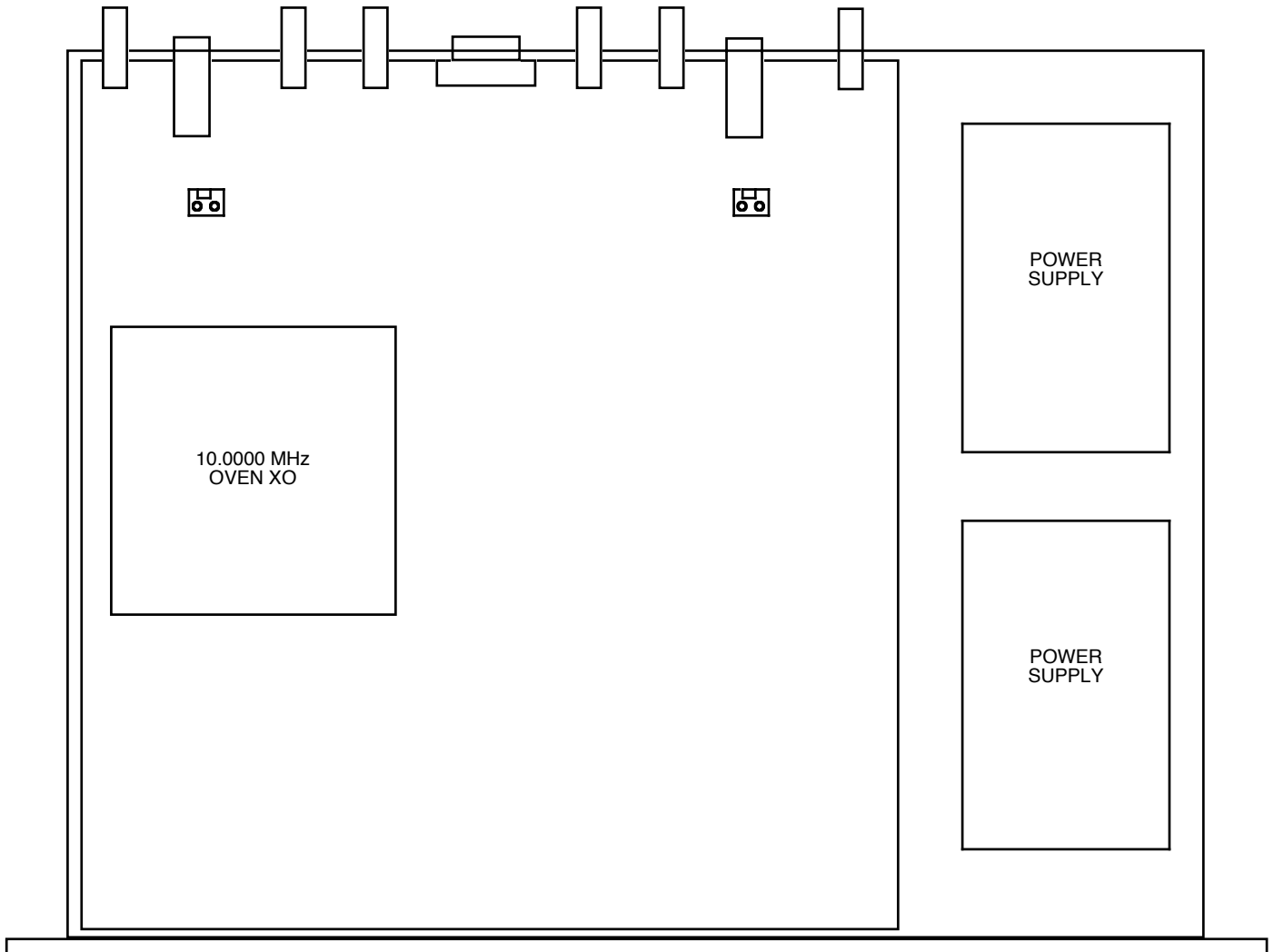

FIGURE 2.0 2099-218 Mechanical Assembly

2.2 Rear Panel Output Signals - Figure 2.1 shows the input and output connectors on the rear panel.

J2 - RF IN

950-2150 MHz input from LNB. Provides LNB voltage and 10MHz ref insertion. F-Type, 75Ω BNC female connector.

F1 - LNB FUSE

0.5A, Fast Blo, 1/4" Fuse. Installing fuse places power (500 mA max) on the RF IN (J2) center

J10 - RF OUT

950-2150 MHz. Capacitively coupled and looped from LNB RF input. F-Type, 75Ω BNC female connector.

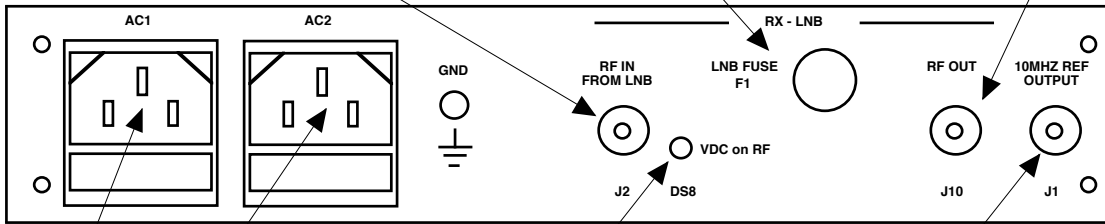

AC1/AC2 - POWER IN

AC input for switching power supply. 100-240 ±10% VAC, 47-60 Hz.

DS8 - LNB VDC INDICATOR

Lights yellow when LNB voltage is present on the RF IN (J2) center pin.

J1 - 10MHZ REF OUTPUT

10 MHz reference output, +3dBm ±3 dB. F-Type, 75Ω BNC female connector.

J10 - MONITOR AND CONTROL

DB9 female connector. see Table 2.0.

J3 - 10 MHz EXT REF

10 MHz external reference input, +3 dBm ±3 dB. 50Ω/75Ω BNC female connector.

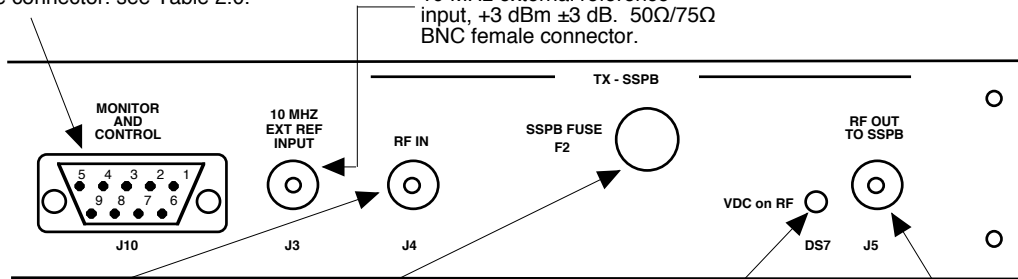

J4 - RF IN

950-2150 MHz input. Capacitively coupled. F-Type, 75Ω BNC female connector.

F2 - SSPB FUSE

1A, Fast Blo, 1/4" Fuse. Installing fuse places power (1 amp max) on the RF OUT (J5) center pin.

DS7 - SSPB VDC INDICATOR

Lights yellow when SSPB voltage is present on the RF OUT (J5) center pin.

J5 - RF OUT TO SSPB

950-2150 MHz output. Looped from RF IN. Provides SSPB voltage and 10MHz ref insertion. F-Type, 75Ω BNC female

FIGURE 2.1 2099-218 Rear Panel Outputs

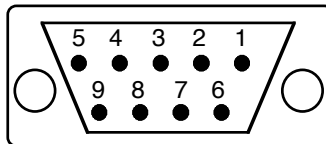

TABLE 2.1 J11 Pinouts (DB9)

Pin	Function
1	Rx-
2	Rx+ (RS-232C)
3	Tx+ (RS-232C)
4	Tx-
5	GND
6	Alarm Relay: Common
7	Alarm Relay: Open=ALARM
8	Not Used
9	Alarm Relay: Closed=ALARM

2.3 Front Panel Indicators -The following are the front panel indicators.

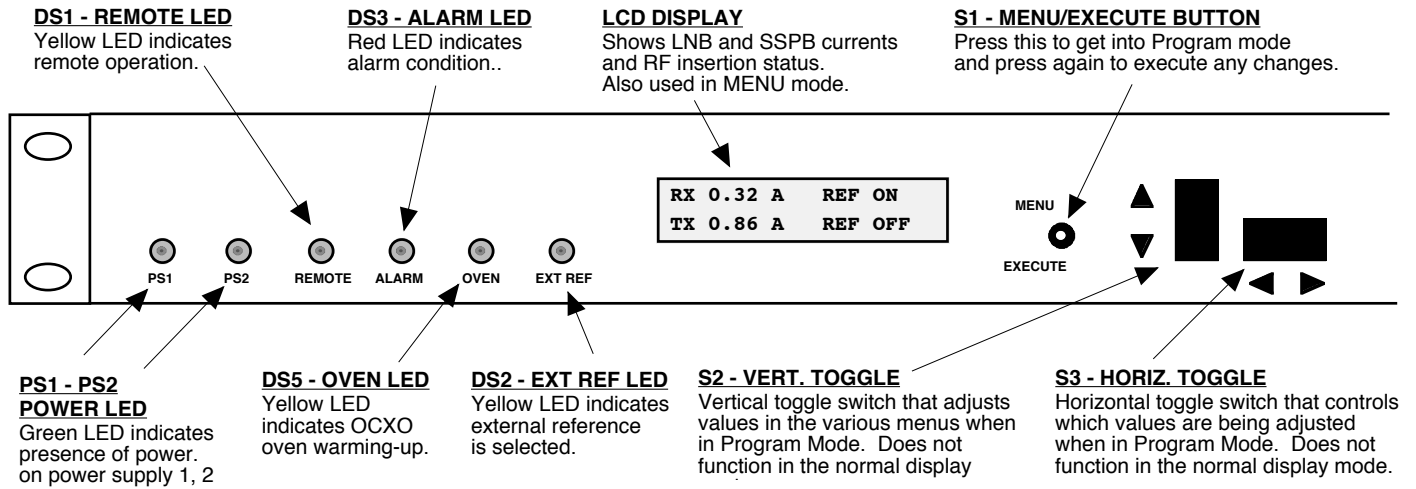

FIGURE 2.2 2099-218 Front Panel Controls and Indicators

2.4 Installation / Operation

2.4.1 Installing and Operating the 2099-218 10MHz Source/Inserter

1. Connect RF IN (FROM LNB), J2, to the LNB (Figure 2.1).
2. Connect RF OUT (TO SSPB), J5, to the SSPB (Figure 2.1).
3. Install 500 mA fast-blo fuse in LNB fuseholder, F1, if power is to be inserted on RX RF IN (FROM LNB), J2.
4. Install 1A fast-blo fuse in SSPB fuseholder, F2, if power is to be inserted on TX RF OUT (TO SSPB), J5.
5. Connect 100-240 \pm 10% VAC, 47 - 63 Hz to AC connector on the back panel.
6. Be sure DS1 (green, POWER) is on (Figure 2.2).
7. Wait for DS5 (yellow, OVEN) to go off and/or contact closure at DB9 ALARM connector, J11, to occur to insure that the oscillator oven is stabilized.
8. AC Fuse - The fuse is a 5 mm X 20 mm, 2 amp slow blow (Type T) and is inserted in the far slot in the drawer below the AC input as shown in Figure 2.3. There is a spare fuse in the near slot. If a fuse continues to open, the power supply is most likely defective.

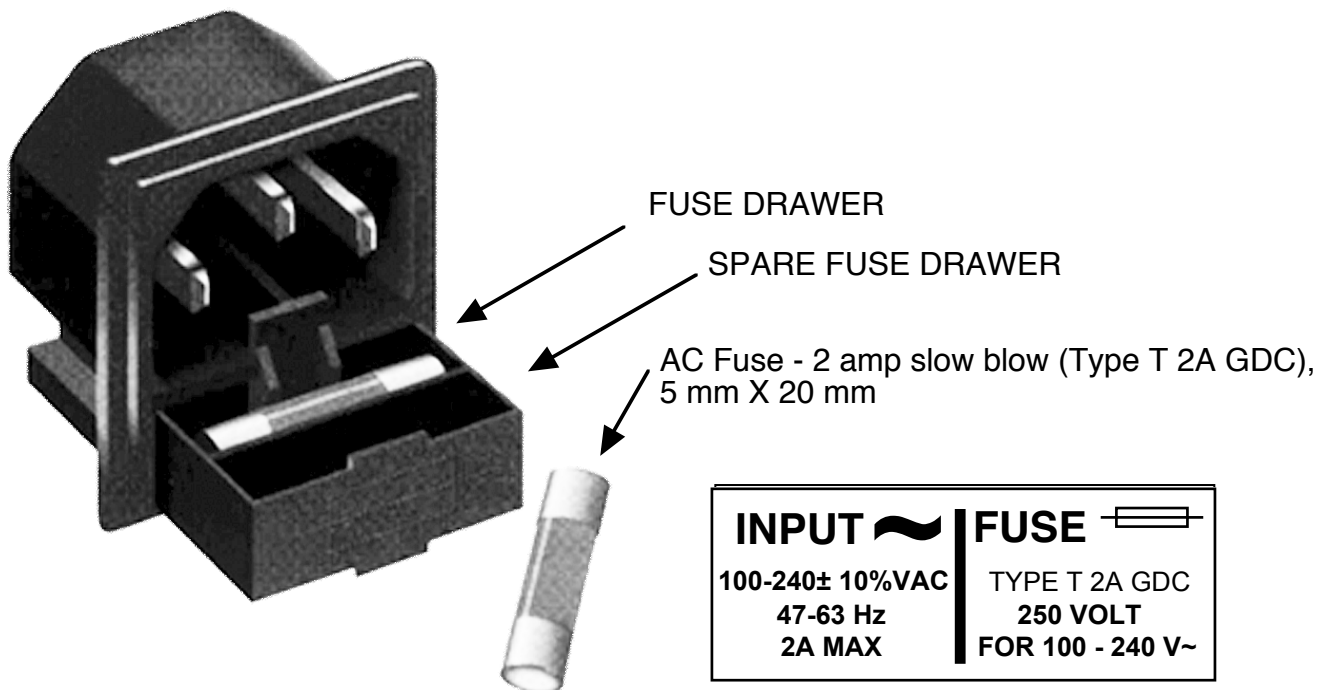

FIGURE 2.3 Fuse Location and Spare Fuse

2.5 Menu Settings

2.5.1 Functions

This section describes operation of the front panel controls. There are three operator switches, the LCD display and alarm indicator LEDs. All functions for the equipment are controlled by these components. The functions are (see Figure 2.4):

Power Up

Normal Display

Menu 1 Set Unit to Remote Operation

Menu 2 Select Internal, External, or Auto 10 MHz Ref

Menu 3 Select Transmit Reference Out

Menu 4 Select Receive Reference Out

Menu 5 Set RS-485 mode (option Q)

Menu 6 Set RS-485 address (option Q)

Menu 7 Reference Offset

Save Menu When “R” is selected from any above menu or at the end

Alarm indications appear on the LED (see Figure 2.2).

All program changes must start with the operation of the Menu/Execute switch and must also end with the operation of the Menu/Execute switch verified by the “**SAVE SETTINGS?**” Menu. If this sequence is not followed, none of the changes will take effect. No program changes will be evident until they are verified at the “**SAVE SETTINGS?**” Menu

2.5.2 Power-On Settings

NOTE: THE LAST STATUS OF A UNIT IS RETAINED EVEN WHEN POWER IS REMOVED. WHEN POWER IS RESTORED, THE UNIT WILL RETURN TO IT'S PREVIOUS SETTINGS.

When power is first applied, the LCD display goes through three steps.

1. The LCD goes black to show all segments are functioning.
2. The software version will be displayed.

REV 1.00

3. The present RX (LNB) and TX (SSPB) current and the 10MHz RF insertion status is shown.

RX 0.32A	REF ON
TX 0.86A	REF OFF

The unit is now operational and ready for any changes the operator may desire.

2.5.3 Control Switches

1. Menu/Execute - Any change to the programming of the unit must be initiated by pressing the Menu/Execute switch and completed by pressing the Menu/Execute switch.
2. Horizontal Switch - This switch is mounted so its movement is horizontal and moves the cursor left or right.
3. Vertical Switch - This switch is mounted so its movement is vertical and will alternately turn any ON/OFF function (such as REMOTE) on or off regardless of the direction operated. In the case of the INT/EXT/AUTO reference setting, the vertical switch will scroll between the three selections.

	ON POWER UP			
Power Up	REV 1.00			
<hr/>				
	NORMAL DISPLAY			
Normal Display	RX 0.32 A REF ON TX 0.86 A REF OFF			PUSH BUTTON
<hr/>				
	PUSHING MENU/EXECUTE SEQUENCE			
Menu 1 Set Unit to Remote Operation	REMOTE OFF R	SCROLL <> SCROLL <>		PUSH BUTTON
Menu 2 Select 10 MHz Reference INT, EXT, or AUTO	INT REF _ R	SCROLL <> SCROLL <>		PUSH BUTTON
Menu 3 Select Transmit Reference Out	TX REF OUT OFF R	SCROLL <> SCROLL <>		PUSH BUTTON
Menu 4 Select Receive Reference Out	RX REF OUT OFF R	SCROLL <> SCROLL <>		PUSH BUTTON
Menu 5 Set Remote Mode (option -Q)	RS 485 OFF R	SCROLL <> SCROLL <>		PUSH BUTTON
Menu 6 Set RS-485 Address (option -Q)	ADDRESS = 00 R	SCROLL <> SCROLL <>		PUSH BUTTON
Menu 7 Reference Offset	FREQ ADJUST Offset = +000 R	SCROLL <>		PUSH BUTTON
Save? When "R" is selected from any above menu or at the end	SAVE SETTINGS? Y N	SCROLL <>		PUSH BUTTON

Figure 2.4 Menu Display and Sequence



6170 Shiloh Road
Alpharetta, Georgia 30005

(770) 886-8005
FAX (770) 886-7964
Toll Free 888-900-5588

WEB www.crosstechnologies.com
E-MAIL info@crosstechnologies.com

2011 Printed in USA