

Instruction Manual

Model 2017-93 Up/Downconverter

May 2010 Rev. D

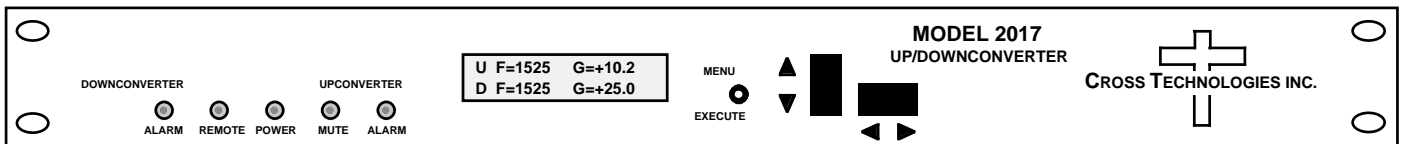

Data, drawings, and other material contained herein are proprietary to Cross Technologies, Inc., but may be reproduced or duplicated without the prior permission of Cross Technologies, Inc. for purposes of operating the equipment. Printed in USA.

When ordering parts from Cross Technologies, Inc., be sure to include the equipment model number, equipment serial number, and a description of the part.



6170 Shiloh Road
Alpharetta, Georgia 30005

(770) 886-8005
FAX (770) 886-7964
Toll Free 888-900-5588

WEB www.crosstechnologies.com
E-MAIL info@crosstechnologies.com

INSTRUCTION MANUAL

MODEL 2017 Up/Downconverter

<u>TABLE OF CONTENTS</u>	<u>PAGE</u>
Warranty	2
1.0 General	3
1.1 Equipment Description	3
1.2 Technical Characteristics	4
1.3 Monitor & Control Interface	5
1.4 Environmental Use Information	8
2.0 Installation	9
2.1 Mechanical	9
2.2 Rear I/O's	10
2.3 Front Panel Controls, Indicators	11
2.4 Operation	12
2.5 Menu Settings	14

WARRANTY - The following warranty applies to all Cross Technologies, Inc. products.

All Cross Technologies, Inc. products are warranted against defective materials and workmanship for a period of one year after shipment to customer. Cross Technologies, Inc.'s obligation under this warranty is limited to repairing or, at Cross Technologies, Inc.'s option, replacing parts, subassemblies, or entire assemblies. Cross Technologies, Inc. shall not be liable for any special, indirect, or consequential damages. This warranty does not cover parts or equipment which have been subject to misuse, negligence, or accident by the customer during use. All shipping costs for warranty repairs will be prepaid by the customer. There are no other warranties, express or implied, except as stated herein.



6170 Shiloh Road
Alpharetta, Georgia 30005

(770) 886-8005
FAX (770) 886-7964
Toll Free 888-900-5588

WEB www.crosstechnologies.com
E-MAIL info@crosstechnologies.com

MODEL 2017-93 Up/Downconverter

1.0 General

1.1 Equipment Description

The 2017-93 L-band Up/Downconverter converts 70 MHz to 950-1525 MHz (up) and 950-1525 MHz to 70 MHz (down) in 1 MHz steps with low group delay and flat frequency response. Synthesized local oscillators (LO) provide frequency selection. Multi-function push button switches select the RF frequency, gain, and other parameters. Front panel LEDs provide indication of DC power (green), PLL alarm for up and downconverters (red), remote operation (yellow), and Upconverter mute (yellow). Gain is manually controlled over a -10.0 to +30.0 dB range for the upconverter (in 0.1 dB steps) and over a 0 to +50 dB range for the downconverter (in 1 dB steps) as adjusted by the front panel multi-function push-button switches. Remote operation allows selection of frequency and gain. Parameter selection and frequency and gain settings appear on the LCD display. Connectors are BNC female for IF and the 10 MHz external reference input and output, and Type F female for RF. LNB +24 VDC (down) and SSPB +24 VDC (up) are inserted on the RF lines when the corresponding rear panel fuse is installed. The 10 MHz reference is also inserted on the RF lines. A high stability (± 0.01 ppm) option is available. Powered by a 100-240 $\pm 10\%$ VAC power supply and housed in a 1.75" X 19" X 16" rack chassis.

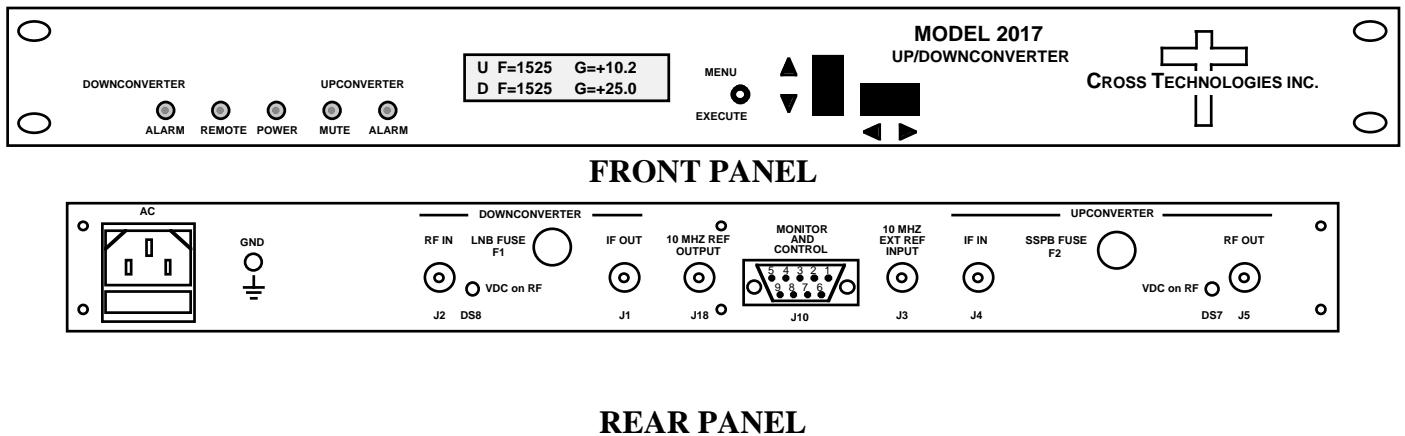

Figure 1.1 Model 2017-93 Front and Rear Panels

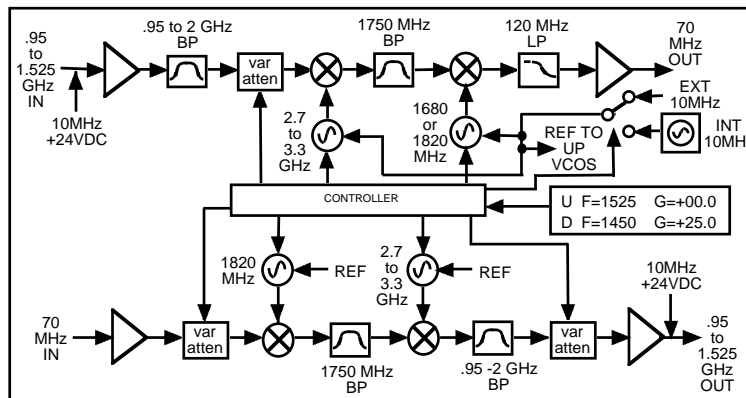

Figure 1.2 Model 2017-93 Up/Downconverter Block Diagram

1.2 Technical Characteristics

TABLE 1.0 2017-95 Up/Downconverter Specifications*

-----UPCONVERTER-----

Input Characteristics (IF)

Impedance/Return Loss 75Ω /18 dB
 Frequency 70 ± 18 MHz
 Input Level -40 to -10 dBm

Output Characteristics (RF)

Impedance/Return Loss 75Ω/10 dB
 Frequency 950 to 1525 MHz
 Output level 0 to -20 dBm
 Output 1 dB compression +5 dBm

Channel Characteristics

Gain range (adjustable) -10 to +30 dB, 1dB steps
 Frequency Sense Non-inverting

-----UP AND DOWNCONVERTER-----

Channel Characteristics

Frequency Response ±1.5 dB, in band; ± 0.5 dB, 36 MHz BW
 Spurious Response <-50 dBC
 Group Delay (max.) 0.01 ns/MHz² parabolic; 0.03 ns/MHz linear; 1 ns ripple

Synthesizer Characteristics

Frequency Accuracy ± 1.0 ppm max. over temp (±0.01 ppm, **option -H**) internal reference
 Frequency Step 1 MHz (125 kHz, **option -X**)

Phase Noise @ Freq	100 MHz	1kHz	10kHz	100kHz	1MHz
dBC/Hz	-70	-70	-80	-90	-100

10 MHz Level (In or Out) 0 dBm ± 3 dB, 75 ohms (**option -E**)

Controls, Indicators

Frequency Selection Direct readout LCD; manual or remote selection
 Gain Selection Direct readout LCD; manual or remote selection
 Power Green LED
 Down/Up Alarm Red LED
 Up Mute Yellow LED
 Remote Yellow LED; RS232C, 9600 baud (RS485, **option -Q**)

Other

RF Connectors Type F (female) (see Table 2.2 for connector options)
 IF Connectors BNC (female) (see Table 2.2 for connector options)
 10 MHz Connectors BNC (female) 50Ω/75Ω (**option -E**)
 Alarm/Remote Connector DB9 (female) - NO or NC contact closure on Alarm
 Size 19 inch, 1RU standard chassis 1.75”H X 16.0”D
 Power 100-240 ±10% VAC, 47-63 Hz, 45 watts max.
 -E External 10 MHz ref input & output with RF insertion
 -H High Stability (±0.01ppm) internal reference
 -L LNB Voltage, +24VDC, 0.4 amps
 -V SSPB Voltage, +24VDC, 2.5 amps
 -Q RS485 Remote Interface
 -T Temperature Sensor
 -W8 Ethernet M&C Remote Interface
 -X 125 kHz frequency step

Connectors/Impedance See Table 2.2

*+10°C to +40°C; Specifications subject to change without notice

-----DOWNCONVERTER-----

Input Characteristics (RF)

Impedance/Return Loss 75Ω /10 dB
 Frequency 950 to 1525 MHz
 Noise Figure (max.) 15 dB (max. gain)
 Input Level -20 to -70 dBm

Input 1 dB compression -15 dBm

Output Characteristics (IF)

Impedance/Return Loss 75Ω /18 dB
 Frequency 70 ± 18 MHz
 Output level/max. linear -20 dBm/-10 dBm
 Output 1 dB compression -5 dBm

Channel Characteristics

Gain Range (adjustable) 0 to +50 dB, 1dB steps
 Image Rejection > 50 dB, min.
 Freq. Sense (selectable) Inverting/Non-inverting

1.3 Monitor and Control Interface

A) Remote serial interface

Protocol: RS-232C, 9600 baud rate, no parity, 8 data bits, 1 start bit, and 1 stop bit.
(RS-232C, RS-422, or **RS-485 - option -Q**)

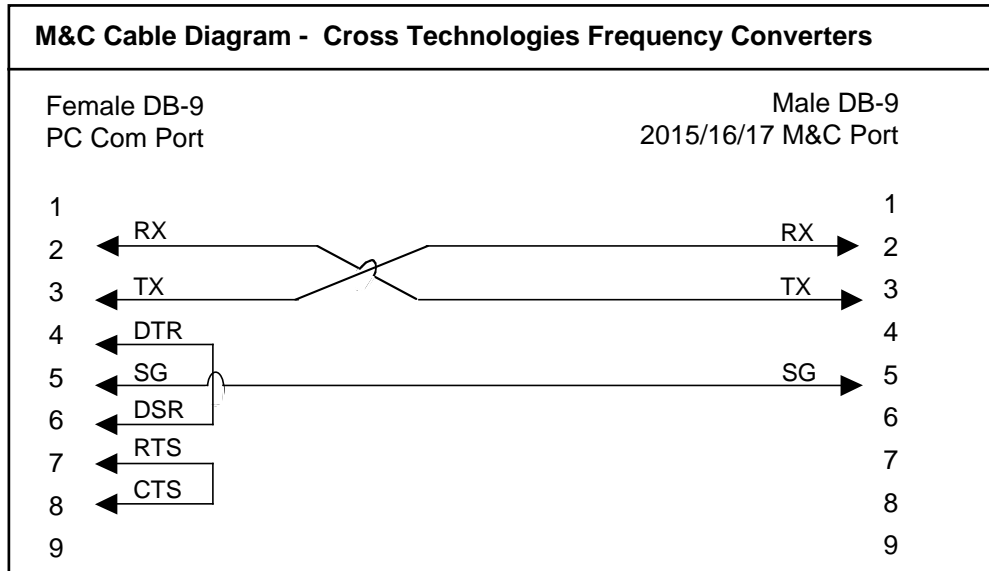

Connector: Rear panel, DB-9 male

J10 Pinouts (RS-232C/422/485)	
Pin	Function
1	Rx-
2	Rx+ (RS-232C)
3	Tx+ (RS-232C)
4	Tx-
5	GND
6	Alarm Relay: Common
7	Alarm Relay: Normally Open
8	Not Used
9	Alarm Relay: Normally Closed

B) Status Requests

Table 1.1 lists the status requests for the 2017-95 and briefly describes them.

* PLEASE NOTE: The two character {aa}(00-31) prefix, in the table below, should be used ONLY when RS-485, (OPTION-Q), is selected.

Table 1.1 2017-93 Status Requests		
Command	Syntax*	Description
Command Status	{aaS1}	Returns {aaS1bbbbccccddddeeeeffLMNOP} where:
		• bbbb = Tx frequency
		• cccc = Rx frequency
		• dddd = Tx gain (-100 to 300)
		• eee = Rx gain (000 to 500)
		• ff = Tx input level (10 to 40)
		• L = 0 - non-inverted Receiver; L = 1 - inverted
		• M = 0 - Receiver synth alarm
		• N = 0 - Transmitter synth alarm
		• O = 0 - Summary alarm
		• P = 0 - Transmit signal disabled (muted)
External 10MHz	{aaS2}	Returns {aaS2bcd} where:
		• b = 1 - External 10MHz selected
		• c = 1 - 10MHz inserted on upconverter RF (J5)
		• d = 1 - 10MHz inserted on downconverter RF (J2)
LNB Current	{aaS3}	Returns {aaS3bb} where:
		• bb = LNB current, range 00 to 50 (0 to 500 ma)
SSPB Current	{aaS4}	Returns {aaS4bbb} where:
		• bbb = SSPB current, range 000 to 250 (0 to 2500 ma)

* PLEASE NOTE: The Address (aa) should only be used when RS-485 is selected (option -Q ONLY)

C) Commands

Table 1.2 lists the commands for the 2017-93 and briefly describes them. After a command is sent the 2017-03 sends a return “>” indicating the command has been received and executed.

General Command Format - The general command format is {aaCND...}, where:

- { = start byte
- aa = address (RS-485 only **option -Q**)
- C = 1 character, either C (command) or S (status)
- N = 1 character command or status request
- D = 1 character or more of data (depends on command)
- } = stop byte

* PLEASE NOTE: The two character {aa}(00-31) prefix, in the table below, should be used ONLY when RS-485, (OPTION-Q), is selected.

Table 1.2 2017-93 Commands		
Command	Syntax*	Description
Set Transmitter Frequency	{aaC1xxxx}	where: • xxxx = 4 characters • Range: 0950 to 1525 MHz
Set Transmitter Input Level	{aaClxx}	where: • xx = 2 characters • Range: 10 to 40 (-10 to -40 dBm)
Set Receiver Frequency	{aaC2xxxx}	where: • xxxx = 4 characters • Range: 0950 to 1525 MHz
Set Transmit Gain	{aaC3xxxx}	where: • xxxx = 3 or 4 characters • Range: -100 to 300 (-10.0 dB to 30.0 dB, in 1 dB steps)
Set Receiver Gain	{aaC4xxx}	where: • xxx = 3 characters • Range: 000 to 500 (00.0 dB to 50.0 dB, in 1 dB steps)
Enable Tx	{aaCAx}	where x =: • 0 to disable Tx signal • 1 to enable Tx signal
External 10MHz	{aaCEx}	where x =: • 0 to disable External 10MHz ref signal • 1 to enable External 10MHz ref signal
Insert 10MHz on UP RF	{aaC5x}	where x =: • 0 to disable 10MHz upconverter insertion on RF (J5) • 1 to enable 10MHz upconverter insertion on RF (J5)
Insert 10MHz on DOWN RF	{aaC6x}	where x =: • 0 to disable 10MHz downconverter insertion on RF (J2) • 1 to enable 10MHz downconverter insertion on RF (J2)
Downconverter Spectrum	{aaC7x}	where x =: • 0 for non-inverted • 1 for inverted
Enable Remote	#	Just # sign
Disable Remote	{aaCRO}	{CR and zero}

* PLEASE NOTE: The Address (aa) should only be used when RS-485 is selected (option -Q ONLY)

1.4 Environmental Use Information

- A. **Rack-Mounting** - To mount this equipment in a rack, please refer to the installation instructions located in the user manual furnished by the manufacturer of your equipment rack.
- B. **Mechanical Loading** - Mounting of equipment in a rack should be such that a hazardous condition does not exist due to uneven weight distribution.
- C. **Elevated Operating Ambient Temperature** - If installed in a closed or multi-unit rack assembly, the operating ambient temperature of the rack may be greater than room ambient temperature. Therefore, consideration should be given to T_{mra} .
- D. **Reduced Air Flow** - Installation of the equipment in a rack should be such that the amount of air flow required for safe operation of the equipment is not compromised. Additional space between unit may be required.
- E. **Circuit Overloading** - Consideration should be given to the connection of the equipment to the supply circuit and the effect that overloading of circuits could have on over current protection and supply wiring. Appropriate consideration of equipment name plate rating should be used when addressing this concern.
- F. **Reliable Earthing** - Reliable earthing of rack-mounted equipment should be maintained. Particular attention should be given to supply connections other than direct connection to the Branch (use of power strips).
- G. **Top Cover** - There are no serviceable parts inside the product so, the Top Cover should not be removed. If the Top Cover is removed the ground strap and associated screw **MUST BE REINSTALLED** prior to Top Cover screw replacement. **FAILURE TO DO** this may cause **INGRESS** and/or **EGRESS** emission problems.

2.0 Installation

2.1 Mechanical - The 2017 consists of one RF/Controller PCB housed in a 1 RU (1 3/4 inch high) by 16 inch deep chassis. A switching, ± 12 , +5, +24 VDC power supply provides power for the assemblies. The 2017 can be secured to a rack using the 4 holes on the front panel. Figure 2.0 shows how the 2017 is assembled.

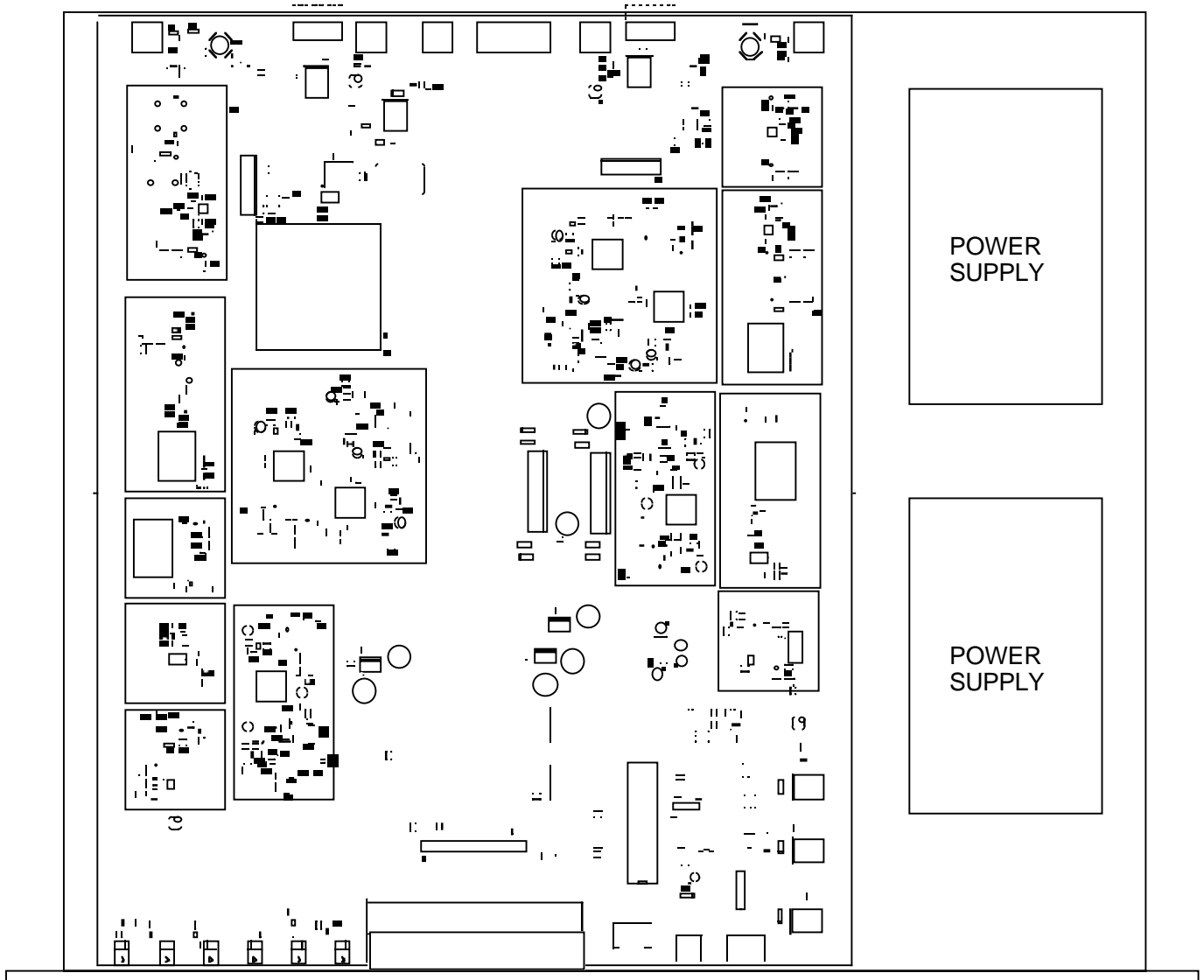

Figure 2.0 Model 2017 Mechanical Assembly

2.2 Rear Panel Input/Output Signals and Level Control - Figure 2.1 shows the input and output connectors on the rear panel.

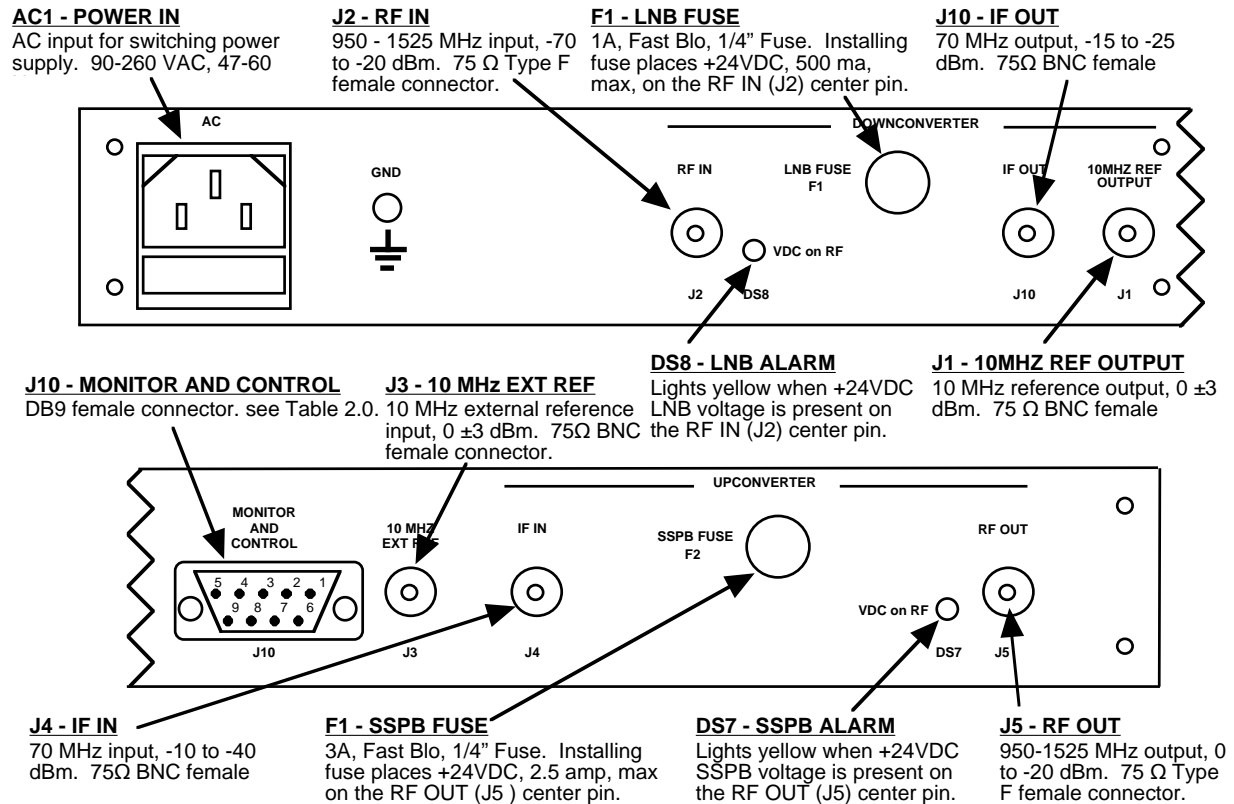

Figure 2.1 Model 2017 Rear Panel I/O's

TABLE 2.1 J10 Pinouts (RS-232C/422/485*)	
Pin	Function
1	Rx-
2	Rx+ (RS-232C)
3	Tx+ (RS-232C)
4	Tx-
5	GND
6	Alarm Relay: Common
7	Alarm Relay: Normally Open
8	Not Used
9	Alarm Relay: Normally Closed

***Remote Serial Interface**

Interface: DB-9 Male

Protocol: RS-232C (RS-232C/422/485 **option -Q**), 9600 baud rate, no parity, 8 data bits, 1 start bit, 1 stop bit.

TABLE 2.2 IF/RF Connector Options		
Option	IF	RF
STD	BNC, 75Ω	Type F, 75Ω
-B	BNC, 75Ω	BNC, 75Ω
-C	BNC, 75Ω	BNC, 50Ω
-D	BNC, 50Ω	BNC, 50Ω
-J	BNC, 50Ω	Type F, 75Ω
-N	BNC, 75Ω	Type N, 50Ω
-M	BNC, 50Ω	Type N, 50Ω

2.3 Front Panel Controls and Indicators - Figure 2.2 shows the front panel controls and indicators.

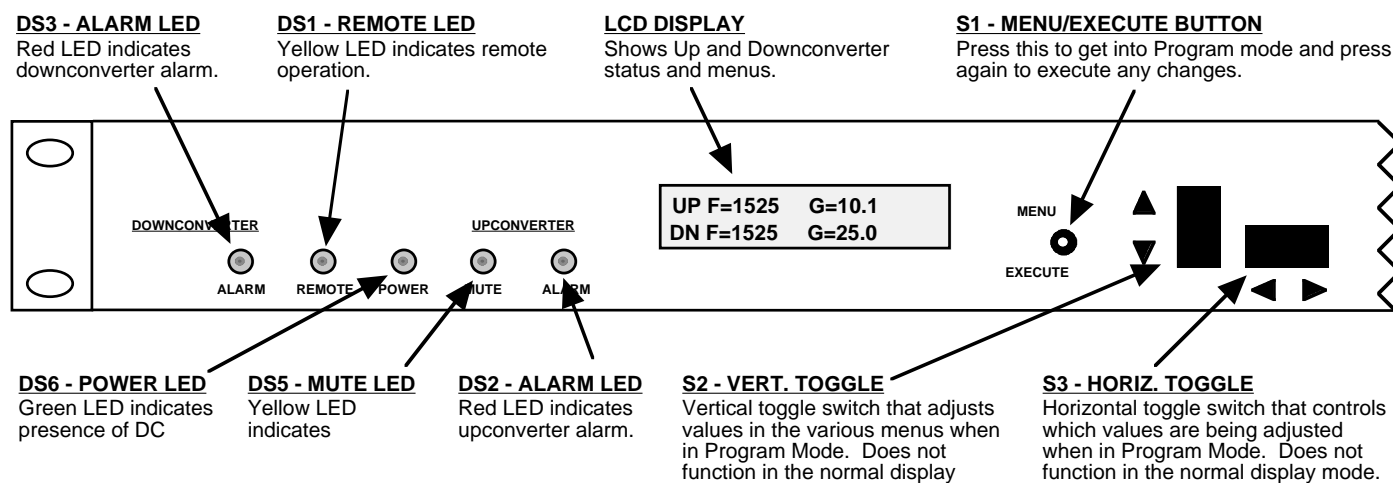

Figure 2.2 Model 2017 Front Panel Controls and Indicators

2.4 Installation / Operation

2.4.1 Installing and Operating the 2017, Upconverter Section

- 1.) Connect a -10 dBm to -40 dBm signal to IF In, J4 (Figure 2.1)
- 2.) Connect the RF OUT, J5, to the external equipment
- 3.) Connect 100-240 \pm 10% VAC, 47 - 63 Hz to AC1 on the back panel.
- 4.) Set the desired output frequency (See Section 2.5 Menu Settings).
- 5.) Set the input level (See Section 2.5 Menu Settings).
- 6.) Set the gain (See Section 2.5 Menu Settings).
- 7.) To power the SSPB (+24 VDC, 2.5 amps, max) from the 2017 install a 3 amp 1/4" fuse in F2.

CAUTION!!! INSTALLING A FUSE IN F2 PUTS +24 VDC, 2.5 AMP POWER ON THE CENTER PIN AND MAY DAMAGE EQUIPMENT IF IMPROPERLY CONNECTED TO EQUIPMENT THAT CANNOT HANDLE THIS VOLTAGE OR HAS A DC PATH TO GROUND.

- 8.) Be sure DS6 (green, DC Power) is on and DS2 (red, Alarm) is off (Figure 2.2).

2.4.2 Installing and Operating the 2017, Downconverter Section -

- 1.) Connect a -70 dBm to -20 dBm signal to RF In, J2 (Figure 2.1)
- 2.) Connect the IF OUT, J1, to the external equipment
- 3.) Connect 90- 260 VAC, 47 - 63 Hz to AC1 on the back panel.
- 4.) Set the desired input frequency (See Section 2.5 Menu Settings).
- 5.) Set the gain to get an output level in the 0 to -20 dBm range (See Section 2.5 Menu Settings).
- 6.) To power the LNB (+24 VDC, 2.5 amps, max) from the 2017 install a 1 amp 1/4" fuse in F1.

CAUTION!!! INSTALLING A FUSE IN F1 PUTS +24 VDC, 0.5 AMP POWER ON THE CENTER PIN AND MAY DAMAGE EQUIPMENT IF IMPROPERLY CONNECTED TO EQUIPMENT THAT CANNOT HANDLE THIS VOLTAGE OR HAS A DC PATH TO GROUND.

- 7.) Be sure DS6 (green, DC Power) is on and DS2 (red, Alarm) is off (Figure 2.2).
- 8.) **AC Fuse** - The fuse is a 5 mm X 20 mm, 2 amp slow blow (Type T) and is inserted in the far slot in the drawer below the AC input as shown in Figure 2.3. There is a spare fuse in the near slot. If a fuse continues to open, the power supply is most likely defective.

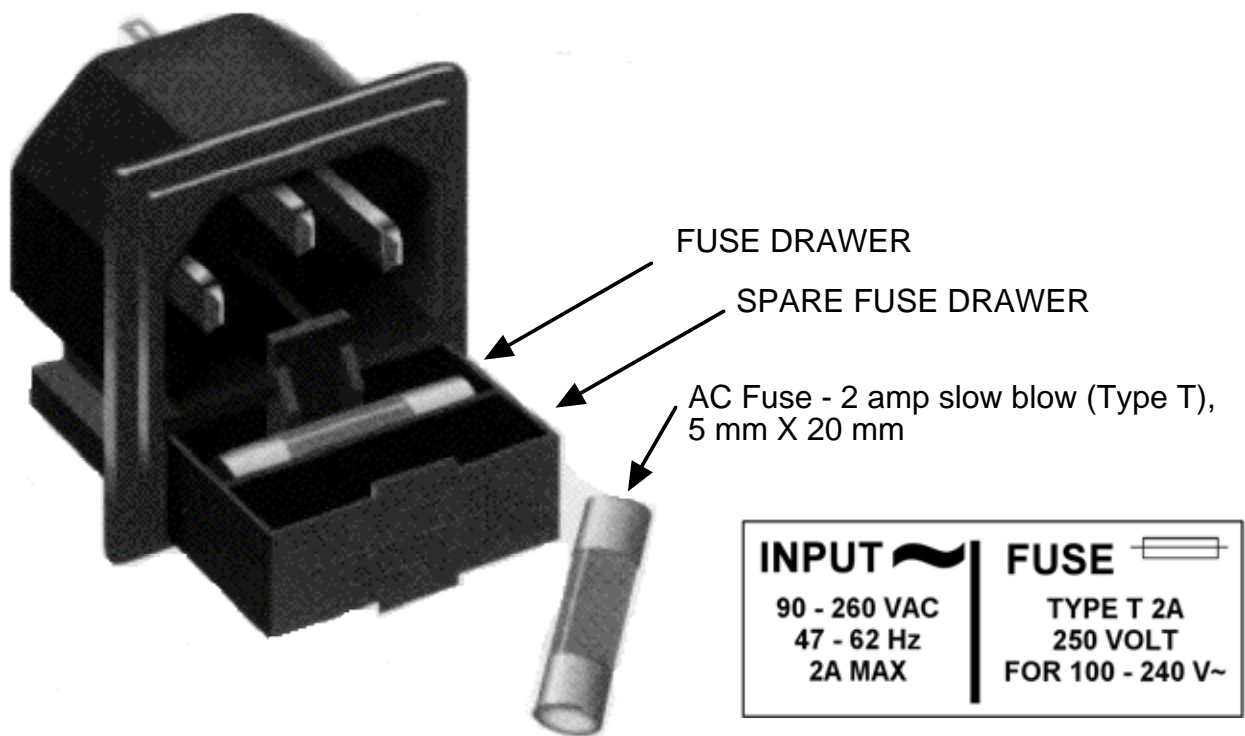

Figure 2.3 Fuse Location and Spare Fuse

2.5 Menu Settings

2.5.1 Functions - This section describes operation of the front panel controls. There are three operator switches, the LCD display and alarm indicator LEDs. All functions for the equipment are controlled by these components. The functions are (see Figure 2.4):

Power Up

Normal Display

- Menu 1** Up Frequency in MHz
- Menu 2** Up Input Lvl (Set from -40 to -10)
- Menu 3** Up Gain (-10 to +30)
- Menu 4** Down Frequency in MHz
- Menu 5** Down Gain (set 0 to +50 for -20 to 0 dBm out range)
- Menu 6** Up Mute
- Menu 7** Set Unit to Remote Operation
- Menu 8** Set Downconverter Spectrum Sense
- Menu 9** Select External 10 MHz Ref
- Menu 10** Upconverter Reference Out
- Menu 11** Downconverter Reference Out
- Menu 12** Set RS-485 mode (option -Q)
- Menu 13** Set RS-485 address (option -Q)
- Menu 14** View PCB Temperature
- Menu 15** View LNB and SSPB Current

Save Menu When go to end

Alarm indications appear on the LEDs (see figure 2.2).

All program changes must start with the operation of the Menu/Execute switch and must also end with the operation of the Menu/Execute switch verified by the "Save Settings?" Menu. If this sequence is not followed, none of the changes will take effect. If programming is initiated and no operator action takes place for approximately 12 seconds (before the final press of the Menu/Execute switch) the display will revert to its previous status and you will need to start over.

2.5.2 Power On Settings

NOTE:The last status of a unit is retained even when power is removed. When power is restored, the unit will return to it's previous settings.

When power is first applied, the LCD display goes through three steps.

- 1.The LCD goes black to show all segments are functioning.
- 2.The software version will be displayed.



REV 1 . 0 0

- 3.The present frequency and gain of the up and downconverter is shown.

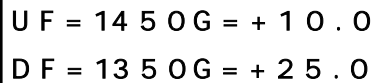

U F = 14 5 0 G = + 1 0 . 0
D F = 13 5 0 G = + 2 5 . 0

The unit is now operational and ready for any changes the operator may desire.

2.5.3 Control Switches

1. Menu/Execute - Any change to the programming of the unit must be initiated by pressing the Menu/Execute switch and completed by pressing the Menu/Execute switch.
2. Horizontal Switch - This switch is mounted so its movement is horizontal and moves the cursor left or right.
3. Vertical Switch - This switch is mounted so its movement is vertical and has two functions:
 - a. During frequency, gain, input level changes, the vertical movement will raise or lower the number in the direction of the arrows.
 - b. For other functions such as TX MUTE ON/OFF, the vertical switch will alternately turn the function on or off regardless of the direction operated.

2.5.4 Frequency Changes

At any time during the modification process, if you have made a mistake and do not wish to save the changes you have made, **do not press the Menu/Execute switch**; simply do nothing for approximately 12 seconds, and the system will return to the normal operating mode or scroll to “**R**” and push the menu/Execute switch and select “**NO**” in the “**SAVE SETTINGS?**” window.

To change the FREQUENCY:

Operate the Menu/Execute switch until you get to the menu item you want to change see Figure 2.4 for the sequence of menu options. The following display is for changing the upconverter frequency:

```
U P   F = 1 1 5 0           R
```

Pressing the Up/Down switch down will toggle the display to:

```
U P   F = 1 2 5 0           R
```

By using the horizontal rocker switch the cursor can be moved left or right .

```
U P   F = 1 2 5 0           R
```

NOTE: CHANGES DO NOT TAKE PLACE ON FREQUENCY UNTIL YOU GO TO THE SAVE MENU AND INDICATE YOU WANT TO SAVE THE CHANGES.

When the display indicates the value desired you can push the Menu/Execute switch to the next item:

```
U P   I N L V L = - 2 0     R
```

NOTE: CHANGES TAKE PLACE ON LEVEL AND GAIN IMMEDIATELY BUT DO NOT GET SAVED UNTIL YOU GO TO THE SAVE MENU AND INDICATE YOU WANT TO SAVE THE CHANGES.

OR you can scroll to “**R**”, push the Menu/Execute switch to get to:

```
S A V E S E T T I N G S ?  Y N
```

Selecting **Y** will save the new settings. Selecting **N** will revert to the previous settings.

Pushing the Menu/Execute switch then takes you to the :

```
U F = 12 5 0 G = + 1 0 . 0  
D F = 13 5 0 G = + 2 5 . 0
```

Figure 2.4 gives the menu items and how to make changes.

2.5.5 Gain Changes

When you get to this menu note that the gain changes will be made as you make them but if you do not wish to save the changes you have made, scroll to “R” and push the menu/Execute switch and select “NO” in the “SAVE SETTINGS?” window or **do not press the Menu/Execute switch**; simply do nothing for approximately 12 seconds, and the system will return to the normal operating mode.

2.5.5.1 Upconverter Gain - To set the upconverter gain, first push the Menu/Execute switch to get to the gain setting:

Operate the Menu/Execute switch until you get to the menu item you want to change see Figure 2.4 for the sequence of menu options.

The following display is for changing the upconverter input level. This is an important setting to optimize spurious and should be made as accurately as possible:

```
UP IN LVL = - 2 0 R
```

Pressing the Up/Down switch to change the level in 1 dB steps and then push the Menu/Execute switch to get to the Gain setting:

```
UP G = + 2 0 . 0 R
```

By using the horizontal rocker switch the cursor can be moved left or right .

Pressing the Up/Down switch down will toggle the display digit selected until you have the desired gain.

NOTE: THE GAIN WILL BE CHANGED AS YOU ADJUST THE NUMBERS. HOWEVER, THE VALUE WILL NOT BE STORED UNTIL YOU INDICATE YES IN THE SAVE SETTINGS WINDOW.DO NOT SET A GAIN THAT WOULD EXCEED A 0 dBm OUTPUT LEVEL.

When the display indicates the value desired you can push the Menu/Execute switch to the next item OR you can scroll to “R”, push the Menu/Execute switch to get to:

```
SAVE SETTINGS? Y N
```

Selecting Y will save the new settings. Selecting N will revert to the previous settings.

Pushing the Menu/Execute switch then takes you to the :

```
UF = 12 5 0G = + 1 0 . 0  
DF = 13 5 0G = + 2 5 . 0
```

2.5.5.2 Downconverter Gain - To set the downconverter gain, first push the Menu/Execute switch to get to the gain setting:

Operate the Menu/Execute switch until you get to the menu item you want to change see Figure 2.4 for the sequence of menu options.

The following display is for changing the downconverter gain. This is an important setting to optimize spurious and should be made as accurately as possible to provide an output in the -20 to 0 dBm level range:

```
D N G = + 2 0 . 0      R
```

Pressing the Up/Down switch to change the level in 1 or 10 dB steps.

By using the horizontal rocker switch the cursor can be moved left or right .

Pressing the Up/Down switch down will toggle the display digit selected until you have the desired gain.

NOTE: THE GAIN WILL BE CHANGED AS YOU ADJUST THE NUMBERS. HOWEVER, THE VALUE WILL NOT BE STORED UNTIL YOU INDICATE YES IN THE SAVE SETTINGS WINDOW.DO NOT SET A GAIN THAT WOULD EXCEED A 0 dBm OUTPUT LEVEL:

When the display indicates the value desired you can push the Menu/Execute switch to the next item OR you can scroll to “R”, push the Menu/Execute switch to get to:

```
S A V E S E T T I N G S ?  Y N
```

Selecting **Y** will save the new settings. Selecting **N** will revert to the previous settings.

Pushing the Menu/Execute switch then takes you to the :

```
U F = 1 2 5 0 G = + 1 0 . 0
D F = 1 3 5 0 G = + 2 5 . 0
```

Figure 2.4 gives the menu items and how to make changes

2.5.5 Alarm Indications

An alarm condition for will occur if any local oscillator phase lock loop (PLL) comes out of lock.

ON POWER UP			
Power Up	REV 1.00		
NORMAL DISPLAY			
Normal Display	U F = 1450 G = +10.0 D F = 1350 G = +25.0		PUSH BUTTON
PUSHING MENU/EXECUTE SEQUENCE			
Menu 1 Up Frequency	UP F = 1450 R	SCROLL <> SCROLL ⬇	PUSH BUTTON
Menu 2 Up Input Level (Set from -40 to -10)	UP INLVL = -20 R	SCROLL <> SCROLL ⬇	PUSH BUTTON
Menu 3 Up Gain (-10 to +30)	UP G = +10.0 R	SCROLL <> SCROLL ⬇	PUSH BUTTON
Menu 4 Down Frequency	DN F = 1350 R	SCROLL <> SCROLL ⬇	PUSH BUTTON
Menu 5 Down Gain (set 0 to +50 for -20 to 0 dBm out level)	DN G = +25.0 R	SCROLL <> SCROLL ⬇	PUSH BUTTON
Menu 6 Up Mute	UP MUTE OFF R	SCROLL <> SCROLL ⬇	PUSH BUTTON
Menu 7 Set Unit to Remote Operation	REMOTE OFF R	SCROLL <> SCROLL ⬇	PUSH BUTTON
Menu 8 Set Downconverter Spectrum Sense	DNSPECTRUM NON R	SCROLL <> SCROLL ⬇	PUSH BUTTON
Menu 9 Select External 10 MHz Reference	EXT REF OFF R	SCROLL <> SCROLL ⬇	PUSH BUTTON
Menu 10 Select Upconverter Reference Out	UP REF OUT OFF R	SCROLL <> SCROLL ⬇	PUSH BUTTON
Menu 11 Select Downconverter Reference Out	DN REF OUT OFF R	SCROLL <> SCROLL ⬇	PUSH BUTTON
Menu 12 Set Remote Mode (option -Q)	RS 485 OFF R	SCROLL <> SCROLL ⬇	PUSH BUTTON
Menu 13 Set RS-485 Address (option -Q)	ADDRESS = 00 R	SCROLL <> SCROLL ⬇	PUSH BUTTON
Menu 14 View PCB Temperature	TEMP = 35 DEG R	SCROLL <>	PUSH BUTTON
Menu 15 View LNB current and SSPB current	LNB DC = 0.32 A SSB DC = 1.86 A R	SCROLL <>	PUSH BUTTON
Save Settings? At the end or when "R" is selected from any of the above menus	SAVE SETTINGS? Y N	SCROLL <>	PUSH BUTTON

Figure 2.4 Menu Display and Sequence

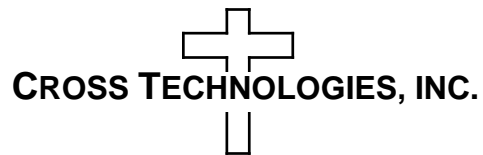

6170 Shiloh Road
Alpharetta, Georgia 30005

(770) 886-8005
FAX (770) 886-7964
Toll Free 888-900-5588

WEB www.crosstechnologies.com
E-MAIL info@crosstechnologies.com

Printed in USA