

Instruction Manual

Model 2015-27 Upconverter

December 2008 Rev A

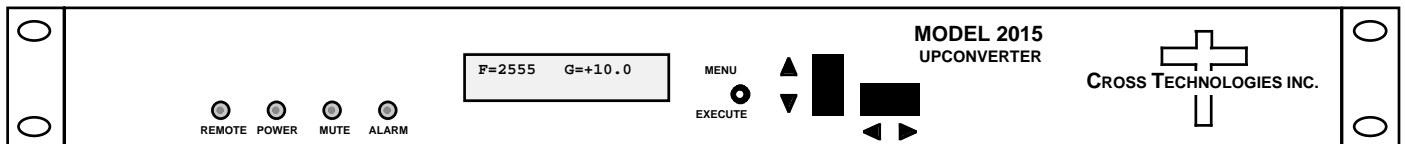

Data, drawings, and other material contained herein are proprietary to Cross Technologies, Inc., but may be reproduced or duplicated without the prior permission of Cross Technologies, Inc. for purposes of operating the equipment.

When ordering parts from Cross Technologies, Inc., be sure to include the equipment model number, equipment serial number, and a description of the part.



6170 Shiloh Road
Alpharetta, Georgia 30005

(770) 886-8005
FAX (770) 886-7964
Toll Free 888-900-5588

WEB www.crosstechnologies.com
E-MAIL info@crosstechnologies.com

INSTRUCTION MANUAL

MODEL 2015-27 Upconverter

<u>TABLE OF CONTENTS</u>	<u>PAGE</u>
Warranty	2
1.0 General	3
1.1 Equipment Description	3
1.2 Technical Characteristics	4
1.3 Monitor & Control Interface	5
1.4 Use Information	8
2.0 Installation	9
2.1 Mechanical	9
2.2 Rear I/O's	10
2.3 Front Panel Controls, Indicators	11
2.4 Operation	12
2.5 Menu Settings	13

WARRANTY - The following warranty applies to all Cross Technologies, Inc. products.

All Cross Technologies, Inc. products are warranted against defective materials and workmanship for a period of one year after shipment to customer. Cross Technologies, Inc.'s obligation under this warranty is limited to repairing or, at Cross Technologies, Inc.'s option, replacing parts, subassemblies, or entire assemblies. Cross Technologies, Inc. shall not be liable for any special, indirect, or consequential damages. This warranty does not cover parts or equipment which have been subject to misuse, negligence, or accident by the customer during use. All shipping costs for warranty repairs will be prepaid by the customer. There are not other warranties, express or implied, except as stated herein.



6170 Shiloh Road
Alpharetta, Georgia 30005

(770) 886-8005
FAX (770) 886-7964
Toll Free 888-900-5588

WEB www.crosstechnologies.com

E-MAIL info@crosstechnologies.com

MODEL 2015-27 Upconverter

1.0 General

1.1 Equipment Description

The 2015-27 Upconverter converts 70 ± 18 MHz to 2500 to 2700 MHz in 1.0 MHz steps (0.125 MHz steps optional) with low group delay and flat frequency response. Synthesized local oscillators (LO) provide frequency selection. Multi-function push button switches select the RF frequency, gain, and other parameters. Front panel LEDs provide indication of DC power (green), PLL alarm (red), Remote operation (yellow) or the TX carrier is Muted (yellow). Variable attenuators for the IF input and output provide a gain range of -10 to +30 dB as adjusted by the front panel multi-function pushbutton switches. Remote operation allows selection of frequency and gain. Parameter selection and frequency and gain settings appear on the LCD display. Connectors are BNC female for IF input, external reference input, and RF output. The 2015-27 is powered by a 100-240 $\pm 10\%$ VAC power supply and is housed in a 1 3/4" X 19" X 16" rack mount chassis.

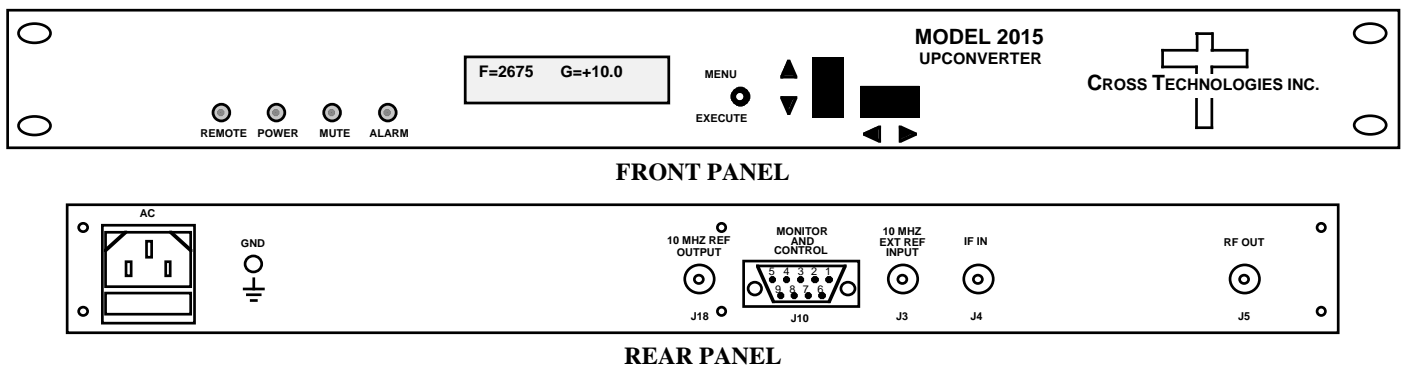

FIGURE 1.1 Model 2015-27 Front and Rear Panels

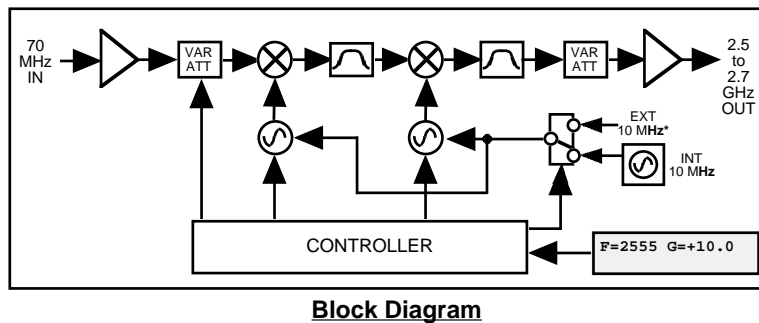

FIGURE 1.2 Model 2015-27 Upconverter Block Diagram

1.2 Technical Characteristics

TABLE 1.0 2015-27 Upconverter Specifications*

Input Characteristics

Impedance/Return Loss	75 Ω /18 dB
Frequency	70 ± 18 MHz
Input Level	-40 to -10 dBm

Output Characteristics

Impedance/Return Loss	50 Ω/12 dB
Frequency	2500 to 2700 MHz
Output level	0 to -20 dBm
Output 1 dB compression	+5 dBm

Channel Characteristics

Gain range (adjustable)	-10 to +30.0 dB
Spurious Response	<-50 dBC
Frequency Response	± 1.5 dB, 2500 - 2700 MHz; ± 0.5 dB, 36 MHz BW
Group Delay, max	0.01 ns/MHz ² parabolic; 0.03 ns/MHz linear; 1 ns ripple
Frequency Sense	Non-inverting

Synthesizer Characteristics

Frequency Accuracy	± 1.0 ppm internal ref (± 0.01 ppm, option H)
Frequency Step	1.0 MHz (125kHz, option X)
10 MHz Level (In/Out)	+3 dBm ± 3 dB (option E)

Phase Noise @ Freq	100 Hz	1kHz	10kHz	100kHz	1MHz
dBC/Hz	-70	-70	-80	-95	-110

Controls, Indicators

Frequency Selection	direct readout LCD; pushbutton switches or remote selection
Gain Selection	direct readout LCD; pushbutton switches or remote selection
Power	Green LED
Alarm	Red LED
Remote	Yellow LED; RS232C, 9600 baud (RS485, option Q)
Mute	Yellow LED

Other

RF Connector	BNC (female), 50Ω
IF Connector	BNC (female), 75Ω
Ext 10 MHz	BNC (female), 50Ω/75Ω (option E)
Connector, Alarm, Remote	DB9 - NO or NC contact closure on Alarm
Size	19 inch, 1RU standard chassis 1.75"high X 16.0" deep
Power	100-240 ±10% VAC, 47-63 Hz, 45 watts max

Options

E	External 10MHz Reference input and output
H	High Stability (±0.01ppm) internal reference
Q	RS-422/RS-485 Remote capability
Z	0.1 dB Attenuator Steps
X	125 kHz Frequency Steps
W8	Ethernet M&C Remote Interface (See separate Ethernet Manual)
Connector options	see TABLE 2.2, page 10

*+10°C to +40°C; Specifications subject to change without notice

1.3 Monitor and Control Interface

A) Remote serial interface

Protocol: RS-232C, 9600 baud rate, no parity, 8 data bits, 1 start bit, and 1 stop bit.

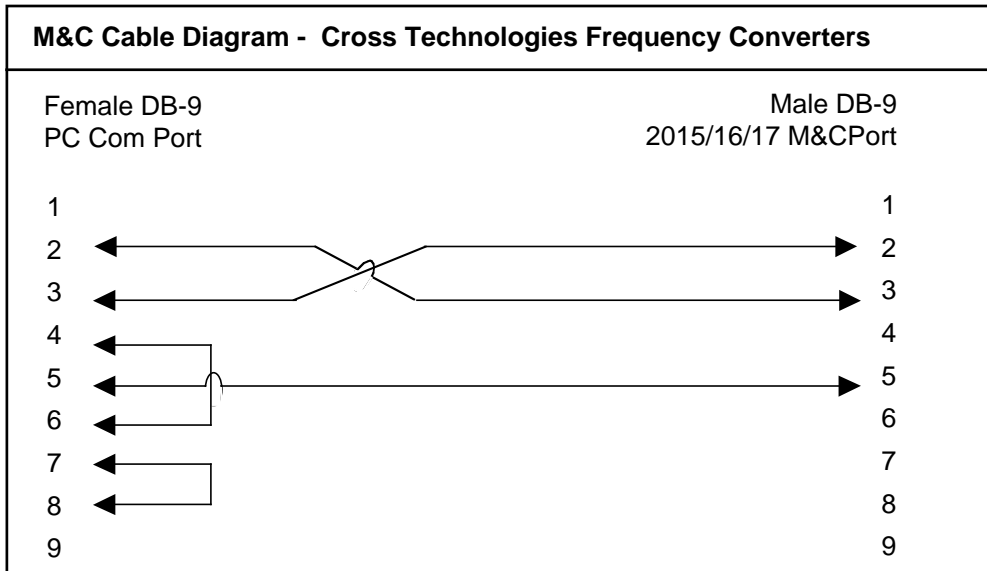

Connector: Rear panel, DB-9 male

J10 Pinouts (RS-232C/422/485)	
Pin	Function
1	Rx-
2	Rx+ (RS-232C)
3	Tx+ (RS-232C)
4	Tx-
5	GND
6	Alarm Relay: Common
7	Alarm Relay: Normally Open
8	Not Used
9	Alarm Relay: Normally Closed

B) Status Requests - Table 1.3 lists the status requests for the 2015-27 and briefly describes them.

* PLEASE NOTE: The two character {aa}(00-31) prefix, in the tables below, should be used ONLY when RS-485, (OPTION-Q), is selected.

Table 1.1 2015-27 Status Requests		
Command	Syntax*	Description
Command Status	{aaS1}	Returns {S1bbbbcccccMEA} where:
		• bbbb = Tx frequency (MHz)
		• ccccc = Tx gain (-10.0 to +30.0)
		• M = Tx RF Status (1 = Normal, 0 = Muted)
		• E = 1 - use external 10 MHz
		• A = 0 - summary alarm

C) Commands Table 1.2 lists the commands for the 2015-27 and briefly describes them. After a command is sent the 2015-27 sends a return “>” indicating the command has been received and executed.

General Command Format - The general command format is {aaCND...}, where:

- { = start byte
- aa = address (**RS-485 only - option Q**)
- C = 1 character, either C (command) or S (status)
- N = 1 character command or status request
- D = 1 character or more of data (depends on command)
- } = stop byte

* PLEASE NOTE: The two character {aa}(00-31) prefix, in the tables below, should be used ONLY when RS-485, (OPTION-Q), is selected.

Table 1.2 2015-27 Commands		
Command	Syntax*	Description
Set Transmitter Frequency	{aaC1xxxx}	where: • xxxx = 4 characters • Range: 2500 to 2700 MHz
Set Input Level	{aaClxx}	where: • xx = 2 characters • Range: 10 to 40 (-10 to -40 dBm, in 1 dB steps)
Set Transmit Gain	{aaC3xxxx}	where: • xxxx = 3 characters (0 to 30dB), 4 characters (-10 to -1dB) • Range: -100 to 300 (-10.0 dB to +30.0 dB, in 1 dB steps)
Enable Tx	{aaCAx}	where x =: • 0 to disable Tx signal • 1 to enable Tx signal
Enable External 10MHz	{aaCEx}	where x =: • 0 to disable External 10MHz ref signal • 1 to enable External 10MHz ref signal
Enable Remote	#	Just # sign
Disable Remote	{aaCRO}	{CR and zero}

1.4 Use Information

- A. Rack-Mounting** - To mount this equipment in a rack, please refer to the installation instructions located in the user manual furnished by the manufacturer of your equipment rack.
- B. Mechanical Loading** - Mounting of equipment in a rack should be such that a hazardous condition does not exist due to uneven weight distribution.
- C. Elevated Operating Ambient Temperature** - If installed in a closed or multi-unit rack assembly, the operating ambient temperature of the rack may be greater than room ambient temperature. Therefore, consideration should be given to T_{mra} .
- D. Reduced Air Flow** - Installation of the equipment in a rack should be such that the amount of air flow required for safe operation of the equipment is not compromised. Additional space between unit may be required.
- E. Circuit Overloading** - Consideration should be given to the connection of the equipment to the supply circuit and the effect that overloading of circuits could have on over current protection and supply wiring. Appropriate consideration of equipment name plate rating should be used, when addressing this concern.
- F. Reliable Earthing** - Reliable earthing of rack-mounted equipment should be maintained. Particular attention should be given to supply connections other than direct connection to the Branch (use of power strips).
- G. Top Cover** - There are no serviceable parts inside the product so, the Top Cover should not be removed. If the Top Cover is removed the ground strap and associated screw **MUST BE REINSTALLED** prior to Top Cover screw replacement. **FAILURE TO DO** this may cause **INGRESS** and/or **EGRESS** emission problems.

2.0 Installation

2.1 Mechanical - The 2015-27 consists of one RF/Controller PCB housed in a 1 RU (1 3/4 inch high) by 16 inch deep chassis. A switching, ± 12 , +24, +5 VDC power supply provides power for the assemblies. The 2015-27 can be secured to a rack using the 4 holes on the front panel. Figure 2.1 shows how the 2015-27 is assembled.

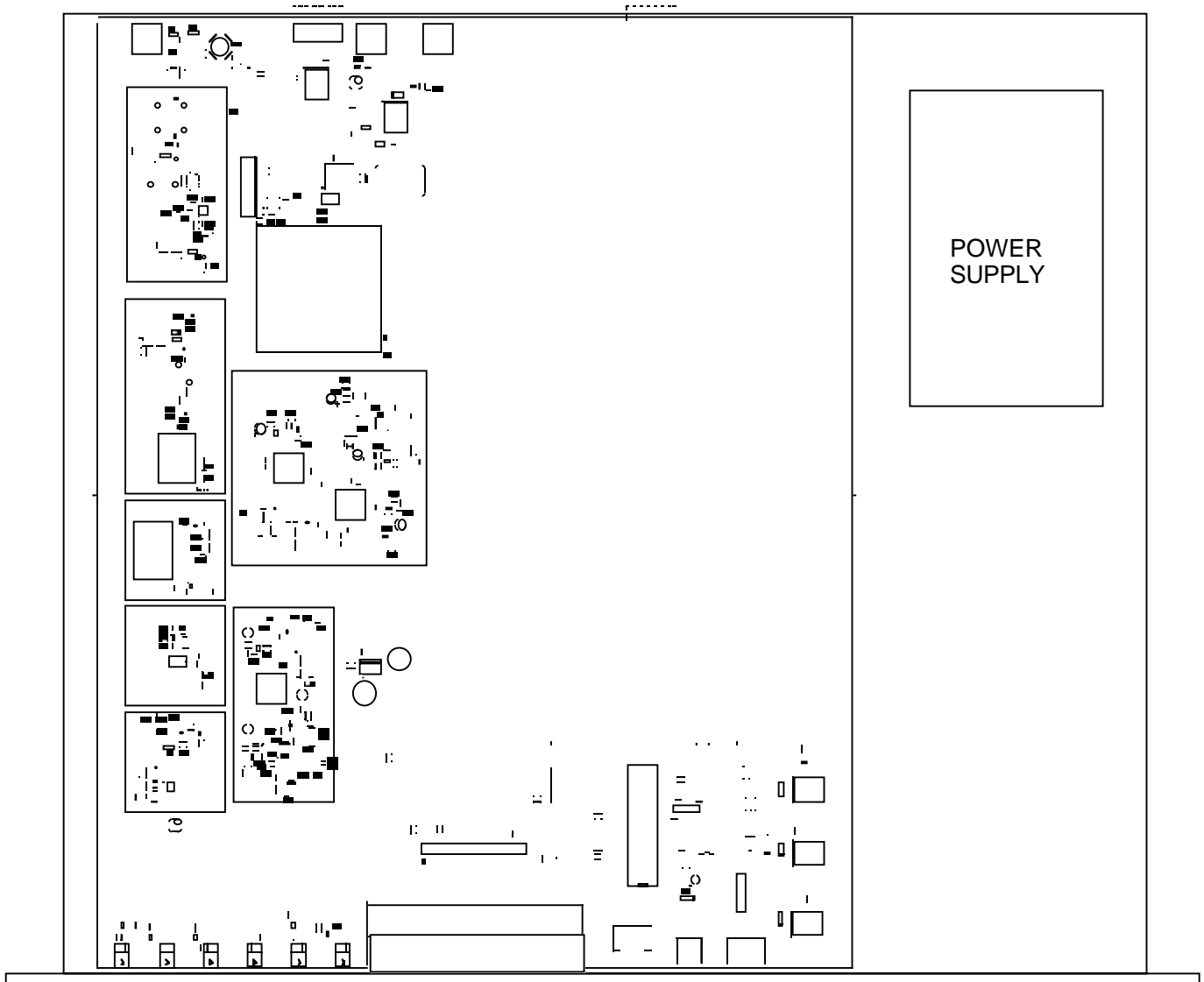

FIGURE 2.1 2015-27 Mechanical Assembly

2.2 Rear Panel Input/Output Signals - Figure 2.2 shows the input and output connectors on the rear panel.

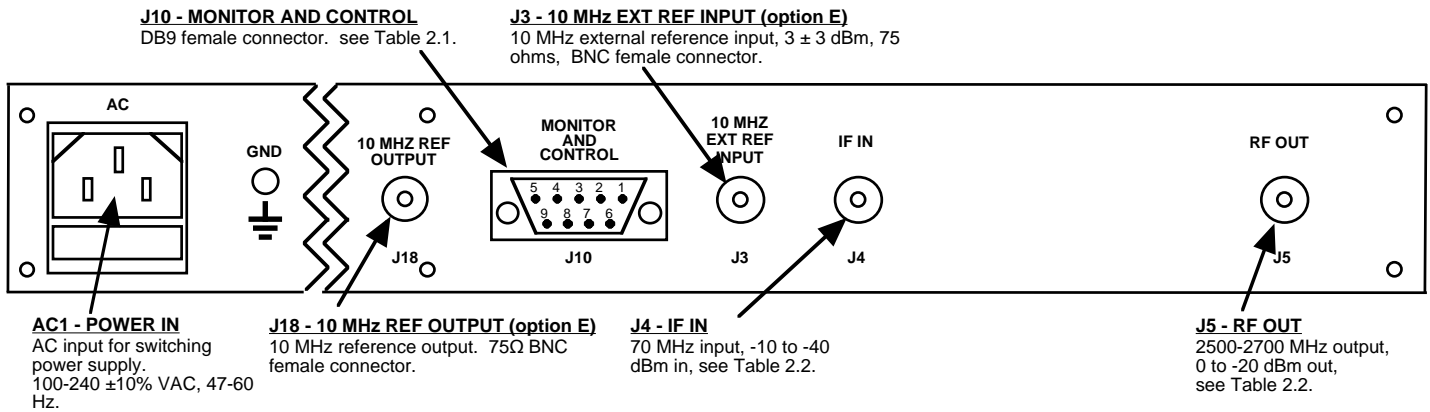

FIGURE 2.2 2015-27 Rear Panel I/Os

TABLE 2.1 J10 Pinouts (RS-232C/422/485*)	
Pin	Function
1	Rx-
2	Rx+ (RS-232C)
3	Tx+ (RS-232C)
4	Tx-
5	GND
6	Alarm Relay: Common
7	Alarm Relay: Normally Open
8	Not Used
9	Alarm Relay: Normally Closed

***Remote Serial Interface**

Interface: DB-9 Male

Protocol: RS-232C (RS-232C/422/485 **option Q**), 9600 baud rate, no parity, 8 data bits, 1 start bit, 1 stop bit.

TABLE 2.2 IF/RF Connector Options		
Option	IF	RF
STD	BNC, 75 Ω	BNC, 50 Ω
-B	BNC, 75 Ω	BNC, 75 Ω
-D	BNC, 50 Ω	BNC, 50 Ω
-N	BNC, 75 Ω	Type N, 50 Ω
-M	BNC, 50 Ω	Type N, 50 Ω
-S	BNC, 50 Ω	SMA, 50 Ω
-SS	SMA, 50 Ω	SMA, 50 Ω

2.3 Front Panel Controls and Indicators - The following are the front panel controls and indicators.

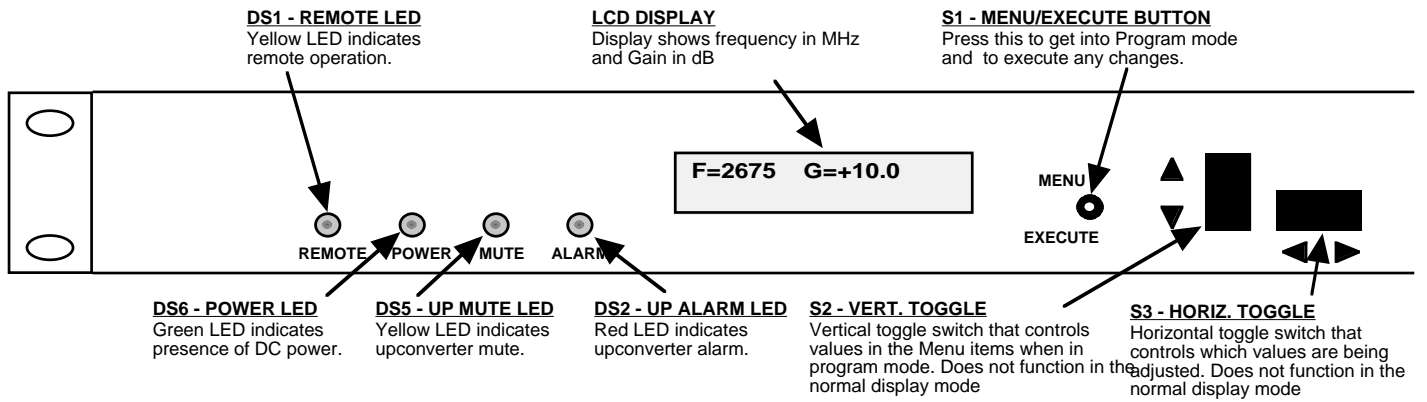

FIGURE 2.3 2015-27 Front Panel Controls and Indicators

2.4 Operation

2.4.1 Installing and Operating the 2015-27 Upconverter

1. Connect a -40 dBm to -10 dBm signal to IF In, J4 (Figure 2.2)
2. Connect the RF OUT, J5, to the external equipment
3. Connect 100-240 \pm 10% VAC, 47 - 63 Hz to AC1 on the back panel.
4. Set the desired output frequency (See Section 2.5 Menu Settings).
5. Set the input level (See Section 2.5 Menu Settings).
6. Set the gain for -10 to +30 dB. Make sure the output stays within -20 to 0 dBm with the gain selected and the input level provided. The firmware will prevent setting gain and input level outside this range. (See Section 2.5 Menu Settings).
7. Be sure DS6 (green, DC Power) is on and DS2 (red, Alarm) is off (Figure 2.3).
8. **AC Fuse** - The fuse is a 5 mm X 20 mm, 2 amp slow blow (Type T) and is inserted in the far slot in the drawer below the AC input as shown in Figure 2.4. There is a spare fuse in the near slot. If a fuse continues to open, the power supply is most likely defective.

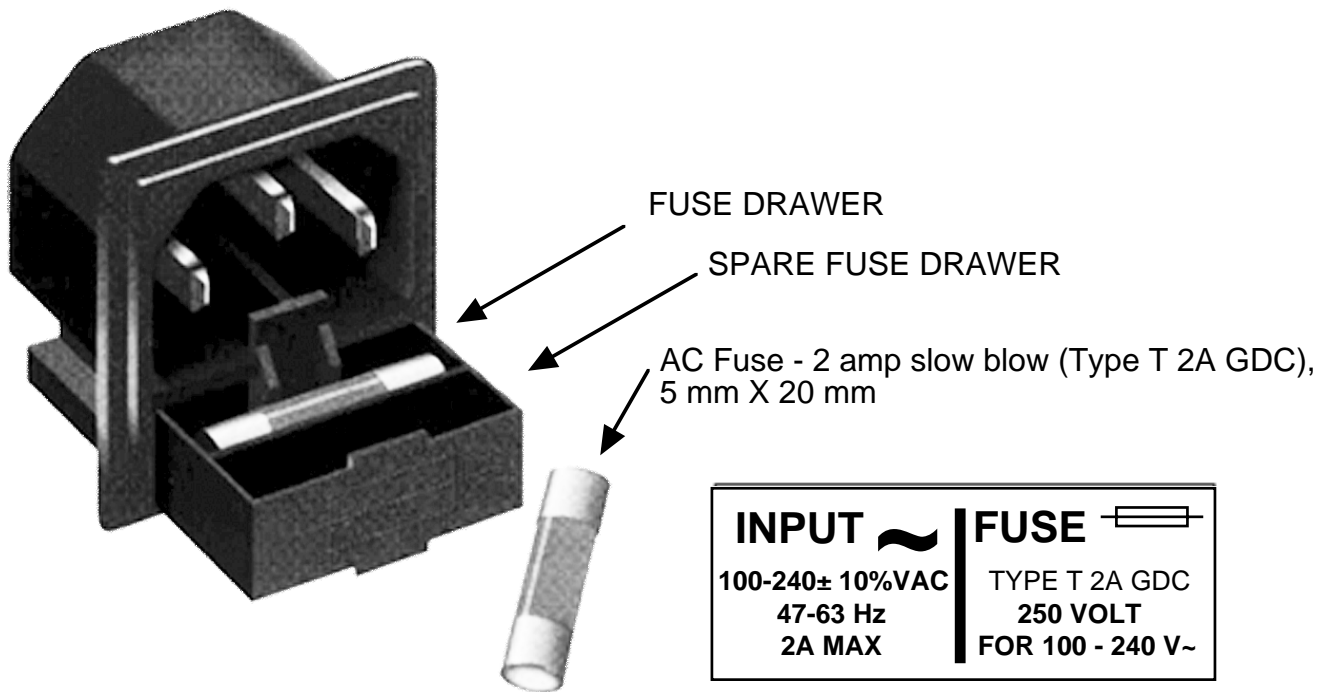

FIGURE 2.4 Fuse Location and Spare Fuse

2.5 Menu Settings

2.5.1 Functions

This section describes operation of the front panel controls. There are three operator switches, the LCD display and alarm indicator LEDs. All functions for the equipment are controlled by these components. The functions are (see Figure 2.5):

Power Up

Normal Display

Menu 1 Frequency in MHz

Menu 2 Input Lvl (Set from -40 to -10)

Menu 3 Gain (-10 to +30)

Menu 4 Mute

Menu 5 Set Unit to Remote Operation (NOTE: the local controls still function when in REMOTE)

Menu 6 Select External 10 MHz Ref (**option E**)

Menu 7 Set Remote Mode (**option Q**)

Menu 8 Set RS-485 Address (**option Q**)

Save Menu When “R” is selected or at the end

Alarm indications appear on the LEDs (see figure 2.3).

All program changes must start with the operation of the Menu/Execute switch and must also end with the operation of the Menu/Execute switch verified by the “Save Settings?” Menu. If this sequence is not followed, none of the changes will take effect. If programming is initiated and no operator action takes place for approximately 12 seconds (before the final press of the Menu/Execute switch) the display will revert to its previous status and you will need to start over.

2.5.2 Power On Settings

NOTE: THE LAST STATUS OF A UNIT IS RETAINED EVEN WHEN POWER IS REMOVED. WHEN POWER IS RESTORED, THE UNIT WILL RETURN TO IT'S PREVIOUS SETTINGS.

When power is first applied, the LCD display goes through three steps.

- 1.The LCD goes black to show all segments are functioning.
- 2.The software version will be displayed.



REV 1.00

- 3.The present frequency and gain of the upconverter is shown.

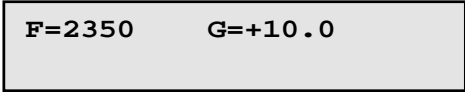

F=2350 G=+10.0

The unit is now operational and ready for any changes the operator may desire.

2.5.3 Control Switches

1. Menu/Execute - Any change to the programming of the unit must be initiated by pressing the Menu/Execute switch and completed by pressing the Menu/Execute switch.
2. Horizontal Switch - This switch is mounted so its movement is horizontal and moves the cursor left or right.
3. Vertical Switch - This switch is mounted so its movement is vertical and has two functions:
 - a. During frequency, gain changes, the vertical movement will raise or lower the number in the direction of the arrows.
 - b. For other functions such Mute on/off, the vertical switch will alternately turn the function on or off regardless of the direction operated.

2.5.4 Frequency Changes

At any time during the modification process, if you have made a mistake and do not wish to save the changes you have made, **do not press the Menu/Execute switch**; simply do nothing for approximately 12 seconds, and the system will return to the normal operating mode or scroll to “**R**” and push the menu/Execute switch and select “**NO**” in the “**SAVE SETTINGS?**” window.

To change the FREQUENCY:

Operate the Menu/Execute switch until you get to the menu item you want to change see Figure 2.5 for the sequence of menu options. The following display is for changing the upconverter frequency:

F = 26<u>5</u>0	R
------------------------	----------

Pressing the Up/Down switch down will toggle the display to:

F = 26<u>4</u>0	R
------------------------	----------

By using the horizontal rocker switch the cursor can be moved left or right .

F = 264<u>0</u>	R
------------------------	----------

NOTE: CHANGES DO NOT TAKE PLACE ON FREQUENCY UNTIL YOU GO TO THE SAVE MENU AND INDICATE YOU WANT TO SAVE THE CHANGES. THE CARRIER IS MUTED WHEN FREQUENCY IS CHANGED.

When the display indicates the value desired you can push the Menu/Execute switch to the next item:

INLVL = -2<u>0</u>	R
---------------------------	----------

OR you can scroll to “**R**”, push the Menu/Execute switch to get to:

SAVE SETTINGS?	<u>Y</u> N
-----------------------	-------------------

Selecting **Y** will save the new settings. Selecting **N** will revert to the previous settings.

Pushing the Menu/Execute switch then takes you to this:

F=2640	G=+00
---------------	--------------

Figure 2.5 gives the menu items and how to make changes.

2.5.5 Gain Changes

When you get to this menu note that the gain changes will be made as you make them but if you do not wish to save the changes you have made, scroll to “**R**” and push the menu/Execute switch and select “**NO**” in the “**SAVE SETTINGS?**” window or **do not press the Menu/Execute switch**; simply do nothing for approximately 12 seconds, and the system will return to the normal operating mode.

The following display is for changing the upconverter input level. This is an important setting to optimize spurious and should be made as accurately as possible:

```
INLVL = -20      R
```

NOTE: CHANGES TAKE PLACE ON LEVEL AND GAIN IMMEDIATELY BUT DO NOT GET SAVED UNTIL YOU GO TO THE SAVE MENU AND INDICATE YOU WANT TO SAVE THE CHANGES.

Pressing the Up/Down switch to change the level in 1 dB steps and then push the Menu/Execute switch to get to the Gain setting:

```
G = +10      R
```

Pressing the Up/Down switch to change the gain in 1 or 10 dB steps and then push the Menu/Execute switch to get to the Gain setting:

```
G = +20      R
```

By using the horizontal rocker switch the cursor can be moved left or right .

Pressing the Up/Down switch down will toggle the display digit selected until you have the desired gain.

NOTE: THE GAIN WILL BE CHANGED AS YOU ADJUST THE NUMBERS. HOWEVER, THE VALUE WILL NOT BE STORED UNTIL YOU INDICATE YES IN THE SAVE SETTINGS WINDOW. DO NOT SET A GAIN THAT WOULD EXCEED 0 dBm OR HAVE LESS THAN -20 dBm OUTPUT LEVEL. THE FIRMWARE PREVENTS YOU FROM THIS.

When the display indicates the value desired you can push the Menu/Execute switch to the next item OR you can scroll to “**R**”, push the Menu/Execute switch to get to:

```
SAVE SETTINGS?  Y N
```

Selecting **Y** will save the new settings. Selecting **N** will revert to the previous settings.

Pushing the Menu/Execute switch then takes you to this:

```
F=2640      G=+10
```

Figure 2.5 gives the menu items and how to make changes.

2.5.5 Alarm Indications

An alarm condition will occur if any local oscillator phase lock loop (PLL) comes out of lock. The Mute LED will light if you select Mute and the Remote LED will light when you select the Remote mode.

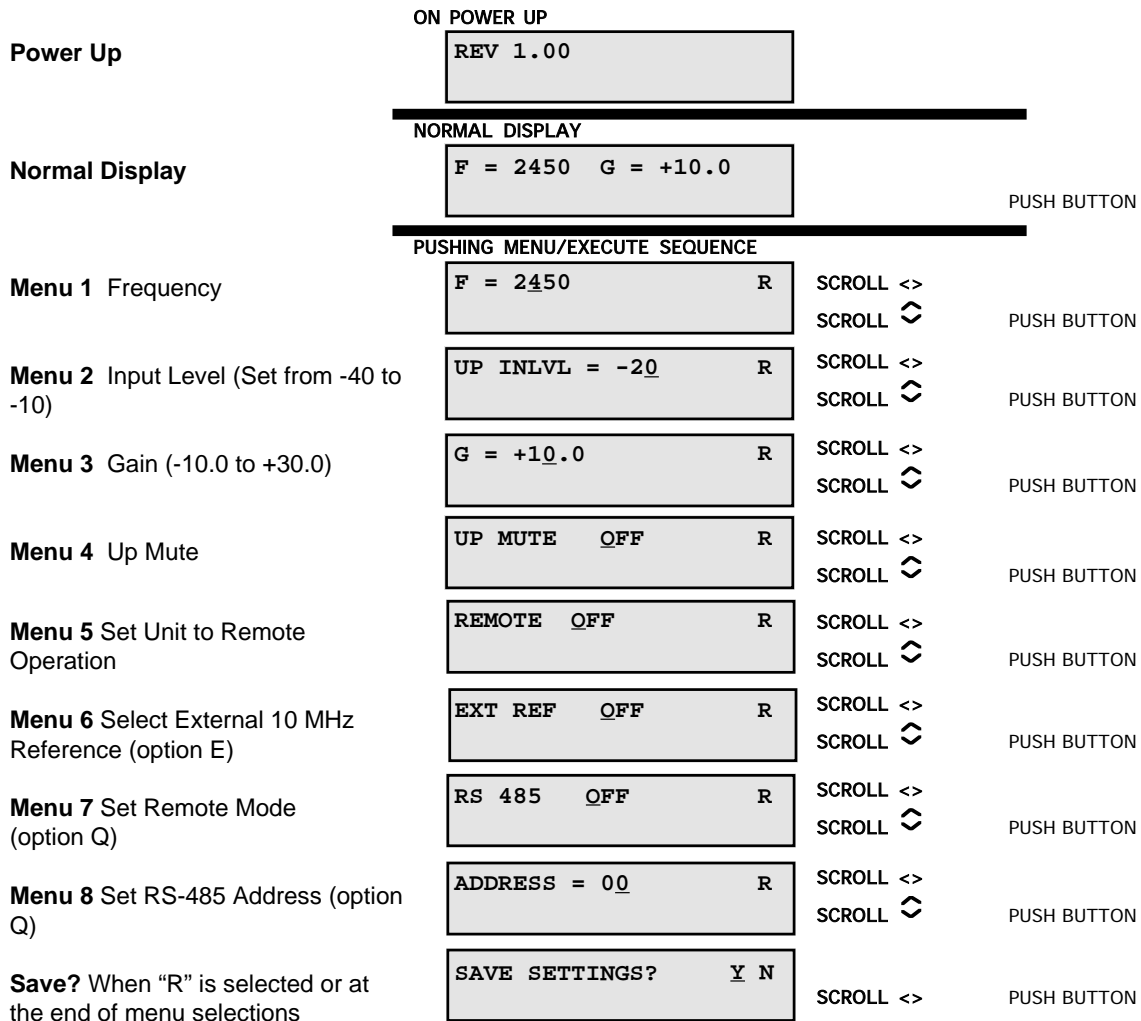

FIGURE 2.5 Menu Display and Sequence



6170 Shiloh Road
Alpharetta, Georgia 30005

(770) 886-8005
FAX (770) 886-7964
Toll Free 888-900-5588

WEB www.crosstechnologies.com
E-MAIL info@crosstechnologies.com