

Instruction Manual

Model 2009-72P-79P Test Downconverter

December 2009, Rev 0

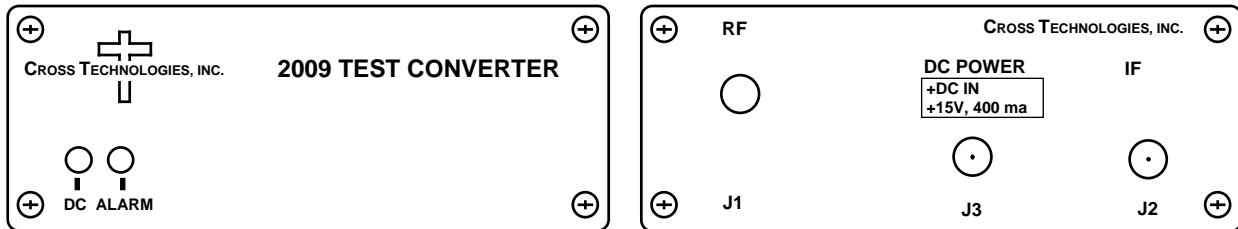

Data, drawings, and other material contained herein are proprietary to Cross Technologies, Inc., but may be reproduced or duplicated without the prior permission of Cross Technologies, Inc. for purposes of operating the equipment. Printed in USA.

When ordering parts from Cross Technologies, Inc., be sure to include the equipment model number, equipment serial number, and a description of the part.



6170 Shiloh Road
Alpharetta, Georgia 30005

(770) 886-8005
FAX (770) 886-7964
Toll Free 888-900-5588

WEB: www.crosstechnologies.com
E-MAIL: info@crosstechnologies.com

MODEL 2009-72P–79P Test Downconverter

<u>TABLE OF CONTENTS</u>	<u>PAGE</u>
Warranty	2
1.0 General	3
1.1 Equipment Description	3
1.2 Technical Characteristics	4
2.0 Installation	5
2.1 Mechanical	5
2.2 Front Panel Indicators	5
2.3 Rear Panel Inputs and Outputs	6
2.4 Accessing the PC Card	6
2.5 Installation/Operation	6
3.0 Environmental Use Information	7

WARRANTY - The following warranty applies to all Cross Technologies, Inc. products.

All Cross Technologies, Inc. products are warranted against defective materials and workmanship for a period of one year after shipment to customer. Cross Technologies, Inc.'s obligation under this warranty is limited to repairing or, at Cross Technologies, Inc.'s option, replacing parts, subassemblies, or entire assemblies. Cross Technologies, Inc. shall not be liable for any special, indirect, or consequential damages. This warranty does not cover parts or equipment which have been subject to misuse, negligence, or accident by the customer during use. All shipping costs for warranty repairs will be prepaid by the customer. There are not other warranties, express or implied, except as stated herein.



6170 Shiloh Road
Alpharetta, Georgia 30005

(770) 886-8005
FAX (770) 886-7964
Toll Free 888-900-5588

WEB: www.crosstechnologies.com
E-MAIL: info@crosstechnologies.com

Model 2009-72P-79P Test Downconverter

1.0 General

1.1 Equipment Description

2009-72P-79P Test Downconverter - These units convert an X-band signal to 950 - 1450 MHz with a low side local oscillator (LO) (non-inverted spectrum). Featuring low phase noise, these units are used to downconvert “clean” (having only this frequency) X-band signals to 950 - 1450 MHz for test purposes. The X-band input is mixed with a synthesized local oscillator. The mixer output is applied to the output amplifier providing a nominal gain of -10 dB. Connectors are 75 ohm BNC female for the 950 - 1450 MHz output and 50 ohm SMA, female for the RF input. Front panel LEDs light when DC power is applied (green) and when a PLL alarm occurs (red). DC power is provided by an external wall mount power supply. The 2009 can be mounted on an 1 3/4” X 19” rack mount panel (**option -R**)

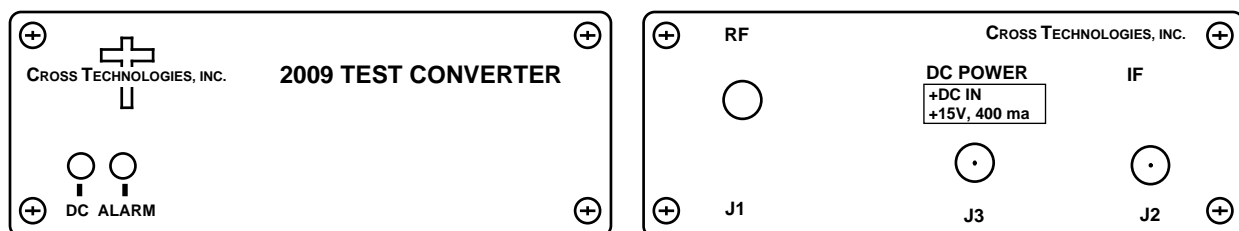

FIGURE 1.1 Front and Rear Panels

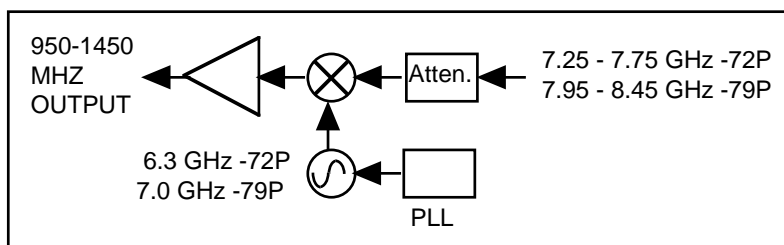

FIGURE 1.2 Block Diagram

1.2 Technical Characteristics

TABLE 1.1 Model 2009-72P-79P Equipment Specifications*

Input Characteristics

Input Impedance/RL	50 Ω/10 dB
Frequency	7.25 - 7.75 GHz (-72P), 7.95 - 8.48 GHz (-79P)
Input Level	-10 to -20 dBm
Input 1 dB compression	0 dBm

Output Characteristics

Impedance/RL	75Ω/12 dB
Frequency Band	950 - 1450 MHz
Level	-20 to -30 dBm

Channel Characteristics

Gain at band center	-10 dB ± 2 dB
Spurious Response	< -40dBC, 950 - 1450 MHz
Frequency Response	±2 dB, 950 - 1450 MHz; ±0.5 dB, any 10 MHz increment

Synthesizer Characteristics

Frequency Accuracy ± 10ppm max

Phase Noise @ Freq	10kHz	100kHz	1MHz
dBC/Hz	-80	-90	-100

Indicators

DC Power	Green LED
Alarm	Red LED

Other

RF In Connector	SMA (female)
RF Out Connector	BNC (female)
Size, Bench Top	4.7" wide X 1.75" high X 6.5" deep
Size, Rack Mount	(-R) 19-inch standard chassis, 1.75"high x 7.0" deep (optional)
Power	120 ± 10% VAC, 60 Hz, 15 watts max, wall mt PS

Models

2009-72P	7.25 - 7.75 GHz in, 950 - 1450 MHz Out, Wall Power Supply
2009-79P	7.95 - 8.45 GHz in, 950 - 1450 MHz Out, Wall Power Supply

*+10°C to +40°C; 2 km max elevation; 90% max humidity; Specifications subject to change without notice

2.0 Installation

2.1 Mechanical

The 2009-72P-79P is packaged in an aluminum extrusion. The **-R option** is mounted on a 1 3/4" X 19" panel that can be mounted to a rack using the 4 holes at the ends (See Figure 2.1).

2.1.1 Cleaning Instructions

Wipe the exterior with a dry, soft cloth. Use no detergent or cleaning chemicals.

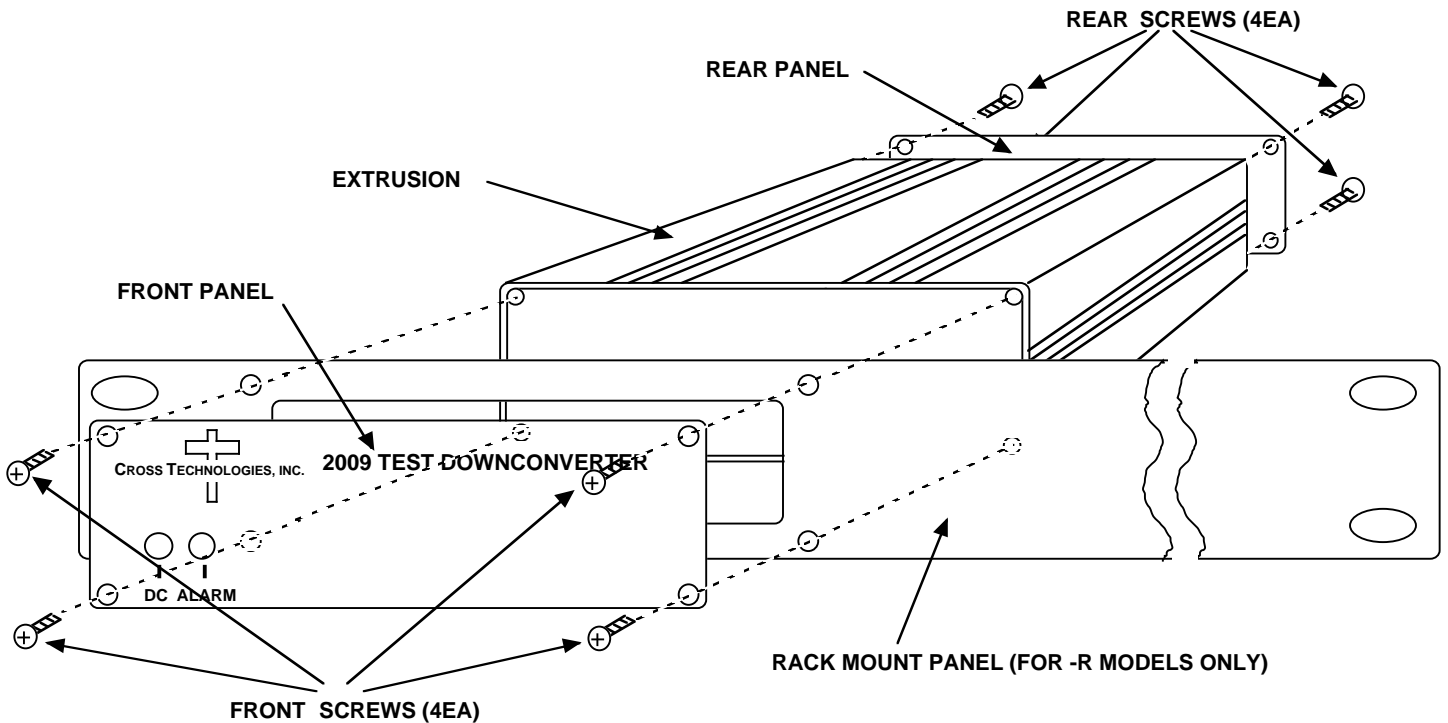

FIGURE 2.1 Model 2009-72P-79P Assembly (-R option shown)

2.2 Indicators

Figure 2.2 shows front panel indicators.

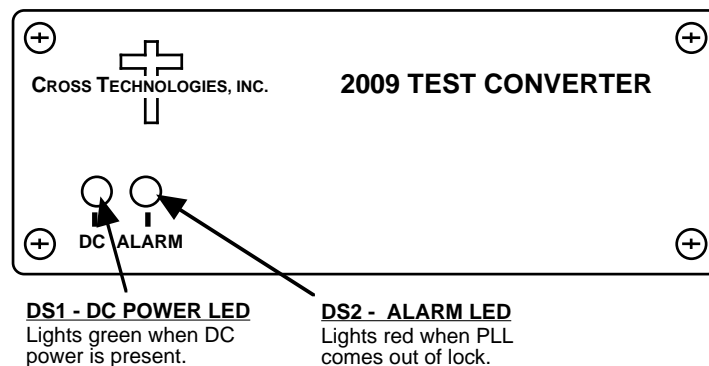

FIGURE 2.2 Model 2009-72P-79P Front Panel Indicators

2.3 Input / Output Signals

Figure 2.3 shows the input and output signals to the 2009-72P-79P.

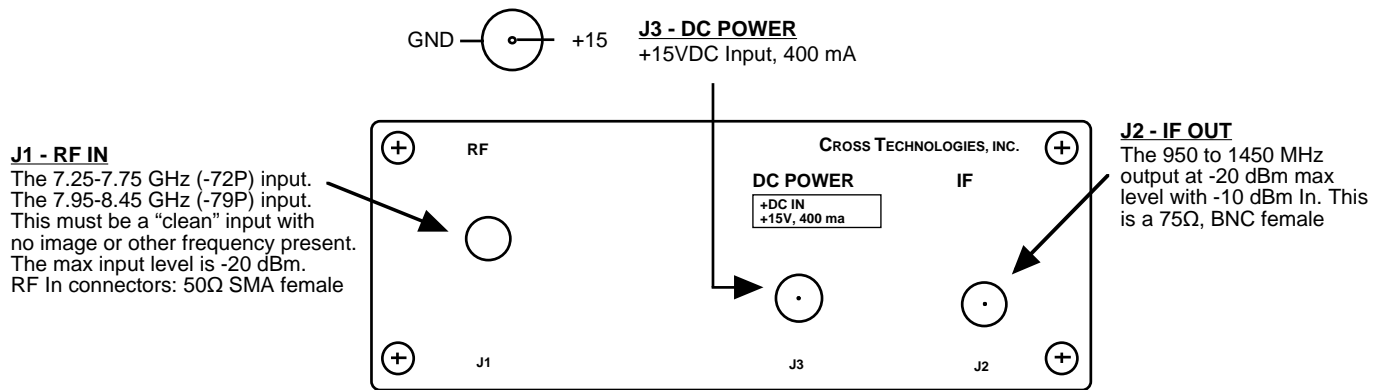

FIGURE 2.3 Model 2009-72P-79P Rear Panel Inputs and Outputs

2.4 Accessing the PC Card

There are NO USER JUMPERS or other on-card controls. ALTHOUGH IT IS NOT RECOMMENDED AND MAY VOID THE WARRANTY the following shows how to remove the printed circuit board (PCB) from the extrusion:

1. **Always remove power** when installing or removing the PCB from the extrusion
2. Remove four (4) **rear panel screws** (see Figure 2.1).
3. **Gently** pull the rear panel and PCB assembly completely out of the extrusion.
4. To install the PCB, **gently** push the rear panel and PCB assembly completely into the extrusion (make sure the shield goes in the lower channel and the PCB in the next channel above that) and that the front panel indicators line up with the front panel holes.
5. Install four (4) **rear panel screws**.

2.5 Installation / Operation

2.5.1 Installing and Operating the 2009-72P-79P

1. For **-P** models, connect one end of the Wall Power Supply to the 2009-72P-79P DC Power In, J3, and the other end to 115 VAC, 60 Hz (Figure 2.3).
2. Connect a -20 dBm, maximum, signal to RF IN, J1 (Figure 2.3).
3. Connect the RF OUT, J2, to the receiver under test.
4. Be sure DS1 (green, DC Power) is on and DS2 (red, Alarm) is off (Figure 2.2).

3.0 Environmental Use Information

- A. **Rack-Mounting** - To mount this equipment in a rack, please refer to the installation instructions located in the user manual furnished by the manufacturer of your equipment rack.
- B. **Mechanical Loading** - Mounting of equipment in a rack should be such that a hazardous condition does not exist due to uneven weight distribution.
- C. **Elevated Operating Ambient Temperature** - If installed in a closed or multi-unit rack assembly, the operating ambient temperature of the rack may be greater than room ambient temperature. Therefore, consideration should be given to Tmra.
- D. **Reduced Air Flow** - Installation of the equipment in a rack should be such that the amount of air flow required for safe operation of the equipment is not compromised. Additional space between unit may be required.
- E. **Circuit Overloading** - Consideration should be given to the connection of the equipment to the supply circuit and the effect that overloading of circuits could have on over current protection and supply wiring. Appropriate consideration of equipment name plate rating should be used, when addressing this concern.
- F. **Reliable Earthing** - Reliable earthing of rack-mounted equipment should be maintained. Particular attention should be given to supply connections other than direct connection to the Branch (use of power strips).
- G. **Top Cover** - There are no serviceable parts inside the product so, the Top Cover should not be removed. If the Top Cover is removed the ground strap and associated screw **MUST BE REINSTALLED** prior to Top Cover screw replacement. **FAILURE TO DO** this may cause **INGRESS** and/or **EGRESS** emission problems.



6170 Shiloh Road
Alpharetta, Georgia 30005

(770) 886-8005
FAX (770) 886-7964
Toll Free 888-900-5588

WEB: www.crosstechnologies.com
E-MAIL: info@crosstechnologies.com

2009 • Printed in USA