

Instruction Manual

Model 2009-140 Downconverter

November 2015, Rev. H

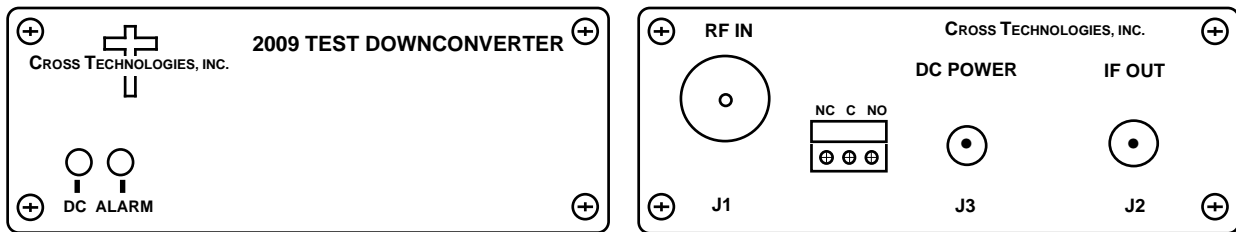

Data, drawings, and other material contained herein are proprietary to Cross Technologies, Inc., but may be reproduced or duplicated without the prior permission of Cross Technologies, Inc. for purposes of operating the equipment.

When ordering parts from Cross Technologies, Inc., be sure to include the equipment model number, equipment serial number, and a description of the part.



6170 Shiloh Road
Alpharetta, Georgia 30005

(770) 886-8005
FAX (770) 886-7964
Toll Free 888-900-5588

WEB www.crosstechnologies.com
E-MAIL info@crosstechnologies.com

INSTRUCTION MANUAL

MODEL 2009-140 Downconverter

<u>TABLE OF CONTENTS</u>	<u>PAGE</u>
Warranty	2
1.0 General	3
1.1 Equipment Description	3
1.2 Technical Characteristics	4
2.0 Installation	5
2.1 Mechanical	5
2.2 Front Panel Indicators	5
2.3 Rear Panel Inputs and Outputs	6
2.4 Accessing the PC Card	6
2.5 Installation/Operation	6
3.0 Environmental Use Information	7

WARRANTY - The following warranty applies to all Cross Technologies, Inc. products.

All Cross Technologies, Inc. products are warranted against defective materials and workmanship for a period of one year after shipment to customer. Cross Technologies, Inc.'s obligation under this warranty is limited to repairing or, at Cross Technologies, Inc.'s option, replacing parts, subassemblies, or entire assemblies. Cross Technologies, Inc. shall not be liable for any special, indirect, or consequential damages. This warranty does not cover parts or equipment which have been subject to misuse, negligence, or accident by the customer during use. All shipping costs for warranty repairs will be prepaid by the customer. There are not other warranties, express or implied, except as stated herein.

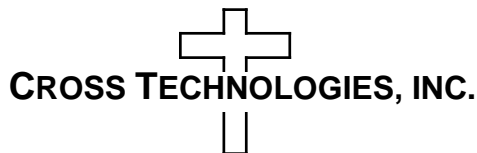

6170 Shiloh Road
Alpharetta, Georgia 30005

(770) 886-8005
FAX (770) 886-7964
Toll Free 888-900-5588

WEB www.crosstechnologies.com
E-MAIL info@crosstechnologies.com

Model 2009-140 Downconverter

1.0 General

1.1 Equipment Description

The 2009-140 Downconverter, for loopback applications, converts a 14.0 - 14.5 GHz signal to 950 - 1450 MHz with a low side local oscillator (LO) (non-inverted spectrum). Featuring low phase noise and high stability, this unit is used to Downconvert “clean” (having only this frequency) 14.0 - 14.5 GHz signals to 950 - 1450 MHz for test purposes. The 14.0 - 14.5 GHz input is mixed with a synthesized local oscillator (LO) signal to 950 - 1450 MHz. The mixer output is applied to the output attenuator providing a nominal gain of -20 dB. Connectors are 75Ω type-F (female) for the 950 - 1450 MHz output and 50Ω type-N (female) for the RF input. Front panel LEDs light when DC power is applied (green) and when a PLL alarm occurs (red). DC power is provided by the LNB voltage from the receiver under test. The 2009-140 can also be powered by an external wall mount power supply (**option -P or -P4**) or the Cross model 2000-01 Power Supply (**option -C**). The 2009 can be mounted on an 1 3/4” X 19” rack mount panel (**option -R**). **Option -H9** allows for the 2009-140 to be operated over an extended -20°C to +60°C temperature range. **Option -W24** Alarm Contact Terminal Strip.

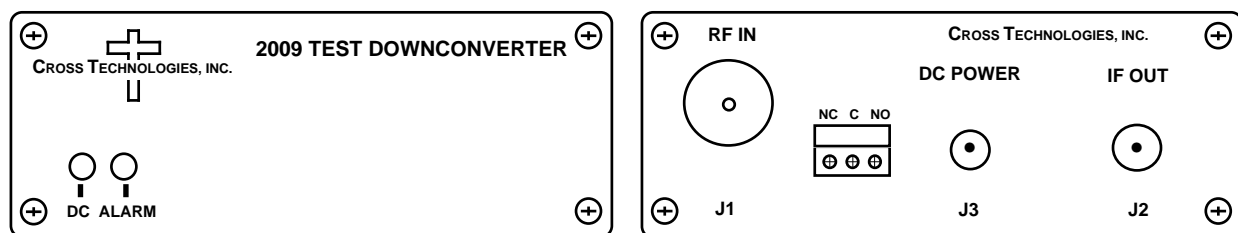

FIGURE 1.1 Front and Rear Panels

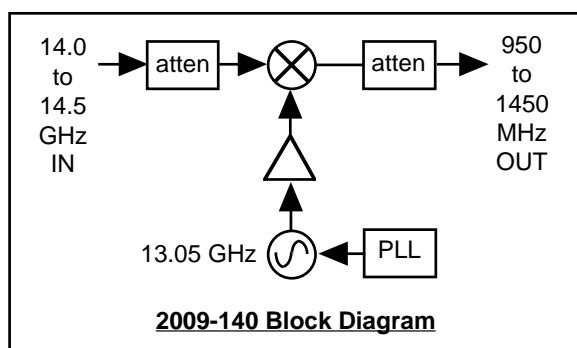

FIGURE 1.2 Block Diagram

1.2 Technical Characteristics

TABLE 1.1 : Model 2009-140 Equipment Specifications*

Input Characteristics

Impedance	50 Ω
Return Loss	12 dB
Frequency	14.0 - 14.5 GHz
Input Level	-15 to 0 dBm
Input 1 dB compression	+5 dBm

Output Characteristics

Impedance	75 Ω
Return Loss	12 dB
Frequency	950 - 1450 MHz
Level	-35 to -20 dBm

Channel Characteristics

Gain at band center	-20 dB ± 2 dB
Spurious Response	< -40 dBC, 950 - 1450 MHz
Spectrum Sense	Non-inverting
Frequency Response	±2 dB, 950 - 1450 MHz; ±0.5 dB, any 10 MHz increment

Synthesizer Characteristics

LO Frequency	13.05 GHz
Frequency Accuracy	± 2.5 ppm max.

Phase Noise @ Freq	10Hz	1kHz	10kHz	100kHz	1MHz
dBC/Hz	-60	-75	-85	-100	-110

Indicators

DC Power	Green LED
Alarm	Red LED

Other

RF Connector	Type N (female)
IF Connector	Type F (female)
Size, Bench Top	4.7" wide X 1.75" high X 6.5" deep
Size, Rack Mount (-R)	19-inch standard chassis, 1.75" high x 7.0" deep (optional)
Power	+15 to +18 VDC, 250 ma on RF Out, (Wall mount power supply optional)

Options

-H9	Operates over an extended -20°C to +60°C temperature range
-P	120 VAC Wall Power Supply, +15 VDC
-P4	100-240 ±10% VAC Wall Power Supply, +15 VDC
-R	1RU Rack Mounting
-C	Power Supply not included. Requires Cross model 2000-01 Power Supply
-W42	Alarm Contact Terminal Strip, Dry Contact, NC-C-NO Terminations

*+10°C to +40°C; 2 km max. elevation; 90% max. humidity; Specifications subject to change without notice.

2.0 Installation

2.1 Mechanical

The 2009-140 is packaged in an aluminum extrusion. The **-R option** is mounted on a 1 3/4" X 19" panel that can be mounted to a rack using the 4 holes at the ends (See Figure 2.1).

2.1.1 Cleaning Instructions

Wipe the exterior with a dry, soft cloth. Use no detergent or cleaning chemicals.

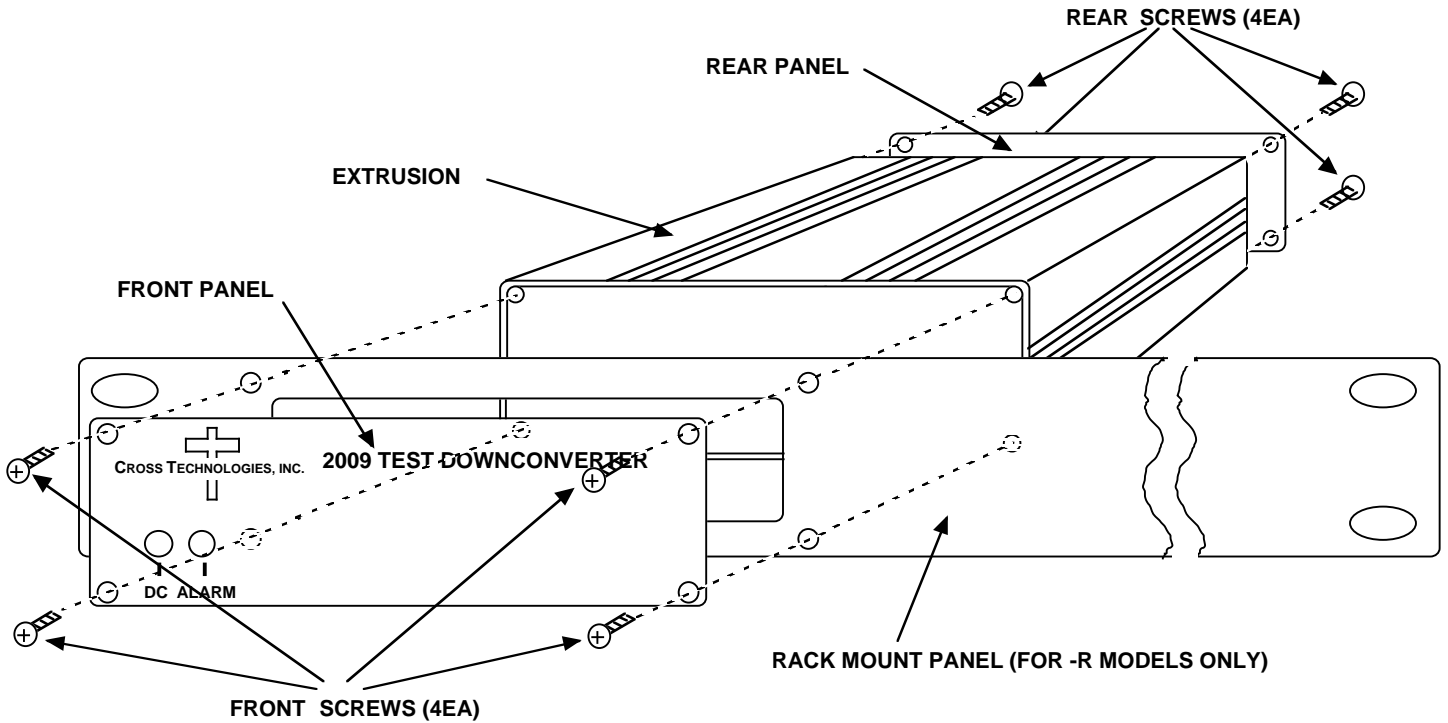

FIGURE 2.1 Model 2009-140 Assembly (-R option shown)

2.2 Indicators

Figure 2.2 shows front panel indicators.

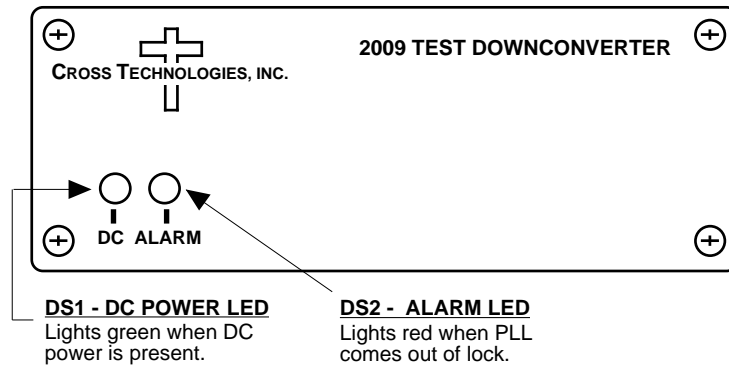

FIGURE 2.2 Model 2009-140 Front Panel Indicators

2.3 Input / Output Signals

Figure 2.3 shows the input and output signals to the 2009-140.

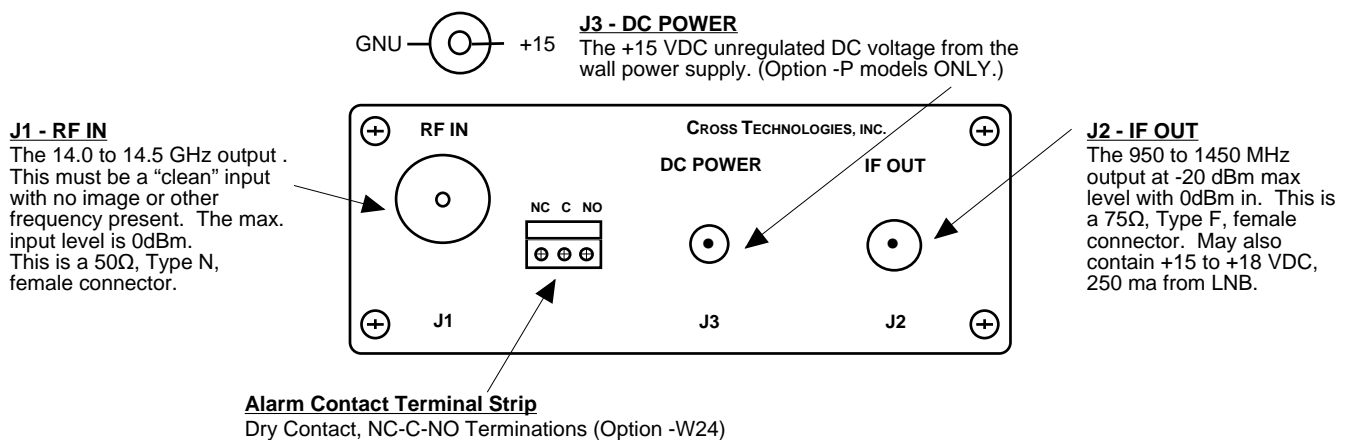

FIGURE 2.3 Model 2009-140 Rear Panel Inputs and Outputs

2.4 Accessing the PC Card

There are NO USER JUMPERS or other on-card controls. ALTHOUGH IT IS NOT RECOMMENDED AND MAY VOID THE WARRANTY the following shows how to remove the printed circuit board (PCB) from the extrusion:

1. **Always remove power** when installing or removing the PCB from the extrusion
2. Remove four (4) **rear panel screws** (see Figure 2.1).
3. **Gently** pull the rear panel and PCB assembly completely out of the extrusion.
4. To install the PCB, **gently** push the rear panel and PCB assembly completely into the extrusion (make sure the shield goes in the lower channel and the PCB in the next channel above that) and that the front panel indicators line up with the front panel holes.
5. Install four (4) **rear panel screws**.

2.5 Installation / Operation

2.5.1 Installing and Operating the 2009-140

1. For **-P** models, connect one end of the Wall Power Supply to the 2009-140 DC Power In, J3, and the other end to 115 VAC, 60 Hz (Figure 2.3).
2. Connect a 0 dBm, maximum signal to RF IN, J1 (Figure 2.3).
3. Connect the IF OUT, J2, to the receiver under test (For models powered from the LNB be sure that the LNB voltage is +15 to +18 VDC, 250 mA max.) (Figure 2.3).
4. Be sure DS1 (green, DC Power) is on and DS2 (red, Alarm) is off (Figure 2.2).

2.5.2 Option W42, Alarm Outputs

This Option, W42, provides an alarm terminal strip on the rear of the unit, with the following three terminals:

NO = Normally Open (Open when there is no alarm condition.)

NC = Normally Closed (Closed when there is no alarm condition.)

C = Common

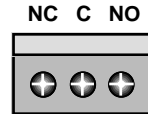

Alarm Contact Terminal Strip

The alarm outputs function as described below:

(Normal Operation)

Power ON *or* NO is Opened (not connected to C)

PLL Locked NC is Closed (connected to C)

(Alarmed Condition)

Power OFF *or* NO is Closed (connected to C)

PLL Alarmed NC is Opened (not connected to C)

3.0 Environmental Use Information

- A. Rack-Mounting** - To mount this equipment in a rack, please refer to the installation instructions located in the user manual furnished by the manufacturer of your equipment rack.
- B. Mechanical loading** - Mounting of equipment in a rack should be such that a hazardous condition does not exist due to uneven weight distribution.
- C. Elevated operating ambient temperature** - If installed in a closed or multi-unit rack assembly, the operating ambient temperature of the rack may be greater than room ambient temperature. Therefore, consideration should be given to T_{mra} .
- D. Reduced air flow** - Installation of the equipment in a rack should be such that the amount of air flow required for safe operation of the equipment is not compromised. Additional space between unit may be required.
- E. Circuit Overloading** - Consideration should be given to the connection of the equipment to the supply circuit and the effect that overloading of circuits could have on over current protection and supply wiring. Appropriate consideration of equipment name plate rating should be used, when addressing this concern.
- F. Reliable Earthing** - Reliable earthing of rack-mounted equipment should be maintained. Particular attention should be given to supply connections other than direct connection to the Branch (use of power strips).
- G. Top Cover** - There are no serviceable parts inside the product so, the Top Cover should not be removed. If the Top Cover is removed the ground strap and associated screw **MUST BE REINSTALLED** prior to Top Cover screw replacement. **FAILURE TO DO** this may cause **INGRESS** and/or **EGRESS** emission problems.



6170 Shiloh Road
Alpharetta, Georgia 30005

(770) 886-8005
FAX (770) 886-7964
Toll Free 888-900-5588

WEB www.crosstechnologies.com
E-MAIL info@crosstechnologies.com

Printed in USA