

# Instruction Manual

# Model 2007/2007R Noise Source

September 2009 Rev. C

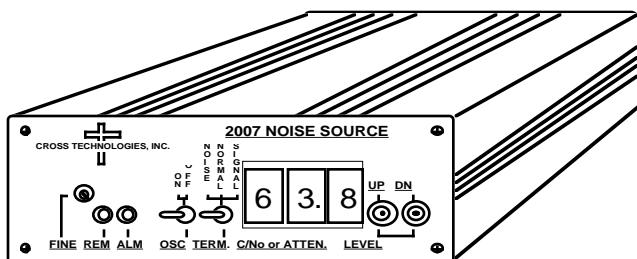

Data, drawings, and other material contained herein are proprietary to Cross Technologies, Inc., but may be reproduced or duplicated without the prior permission of Cross Technologies, Inc. for purposes of operating the equipment. Printed in USA.

When ordering parts from Cross Technologies, Inc., be sure to include the equipment model number, equipment serial number, and a description of the part.



6170 Shiloh Road  
Alpharetta, Georgia 30005

(770) 886-8005  
FAX (770) 886-7964  
Toll Free 888-900-5588

WEB [www.crosstechnologies.com](http://www.crosstechnologies.com)  
E-MAIL [info@crosstechnologies.com](mailto:info@crosstechnologies.com)

# INSTRUCTION MANUAL

## MODEL 2007 Noise Source

### TABLE OF CONTENTS

	<u>PAGE</u>
Warranty	2
1.0 General	3
1.1 Equipment Description	3
1.2 Technical Characteristics	4
2.0 Installation	5
2.1 Mechanical	5
2.2 Control and Indicators	5
2.3 Input/Output Signals	5
2.4 Jumper Settings	5
2.5 Installation/Operation	7
2.5.1 Local Operation	7
2.5.2 Noise Level setting, Continuous Mode	8
2.5.3 Noise Level Setting, Preset Level Mode	8
2.5.4 Selecting Filter Bandwidths	8
2.5.5 Remote Operations	8
2.5.6 Remote Control DOS Program	9
3.0 Circuit Description	11
3.1 Block Diagram Description	11
3.2 Controller Operation for the 2007	11
3.2.1 General	11
3.2.2 Noise Level setting, Continuous Mode	12
3.2.3 Noise Level Setting, Preset Level Mode	12
3.2.4 Selecting Filter Bandwidths	12
4.0 Environmental Use Information	14

**WARRANTY** - The following warranty applies to all Cross Technologies, Inc. products.

All Cross Technologies, Inc. products are warranted against defective materials and workmanship for a period of one year after shipment to customer. Cross Technologies, Inc.'s obligation under this warranty is limited to repairing or, at Cross Technologies, Inc.'s option, replacing parts, subassemblies, or entire assemblies. Cross Technologies, Inc. shall not be liable for any special, indirect, or consequential damages. This warranty does not cover parts or equipment which have been subject to misuse, negligence, or accident by the customer during use. All shipping costs for warranty repairs will be prepaid by the customer. There are not other warranties, express or implied, except as stated herein.

# MODEL 2007 NOISE SOURCE

## GENERAL

### **1.1 Equipment Description**

The Model 2007 Noise Source provides 70 MHz band limited noise in 0.1dB increments and summing of an external signal. Broad band noise goes to precision attenuators controlled by front panel “up” and “down” pushbutton switches via the microprocessor controller. The front panel display shows C/No or attenuation of the noise from a 50 dB- Hz C/No level calibrated for a -20.0 dBm carrier level. Bandpass filters are selected with on board jumpers to band limit the noise at 70 MHz. The 2007 has a front panel red LED that lights if the ambient temperature is outside the +15 to +40 C calibrated temperature range. A yellow LED on the front panel indicates if in remote operation.

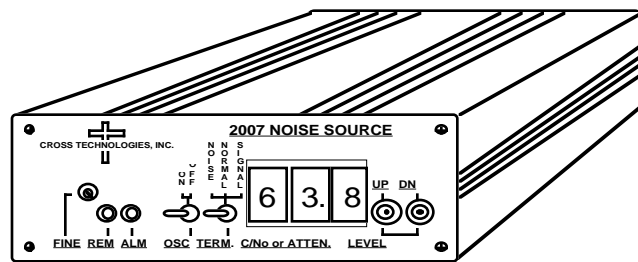

**Figure 1.1 2007 Noise Source Chassis**

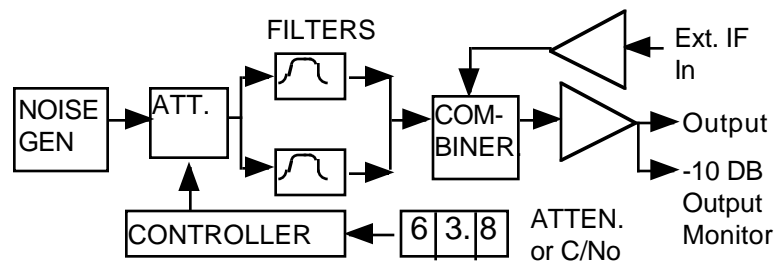

**Series 2007 Noise Source Block Diagram**

## 1.2 Technical Characteristics

**TABLE 1.0 2007, 2007R Noise Source Specifications\***

### Equipment Features

- 10 MHz bandwidth at 70 MHz center frequency
- Accurate attenuator provides 0.1 dB steps of noise power
- Display shows C/No or attenuation from maximum noise power

### Input Characteristics - Carrier Input

Impedance/Return Loss	75 $\Omega$ 15 db
Frequency	70 MHz center
Input Level	-20 dBm
Gain	0 db $\pm$ 0.1 dB

### Output Characteristics

Impedance/Return Loss	75 $\Omega$ /15 dB
Frequency Band	52 - 88 MHz
Level	noise power range allows C/No range of 50 to 90 dB-Hz with a -20.0 dBm carrier
Monitor Level	-10 dB down from main output

### Channel Characteristics - Noise Source

Selectable BW(MHz)	10 MHz or 40 MHz @ 70 MHz
Frequency Response	$\pm$ 0.5 dB, 8 MHz, 36 MHz
Noise Accuracy	$\pm$ .025 dB 15 to 40 deg C; $\pm$ 0.5 dB, 10 to 15, 40 to 50 deg C
Noise Power Stability	$\pm$ 0.5 dB, 15 to 40 deg C, 30 days

### Controls

Test Carrier	Toggle switch turns reference 70 MHz carrier on and off
Term Noise or Carrier	Toggle switch terminates noise or external signal
Output Level	Potentiometer for Noise calibration
Attenuation	PB switches w/readout of attenuator or C/No setting

### Indicators

Alarm	Red LED for temp range (with FET open drain)
Remote	Yellow LED lights when remote control of noise power level is selected
Level	Three digit displays show C/No for a -20.0 dBm carrier or attenuation from max. noise level

### Other

RF, IF Connectors	BNC, female
Size, Bench Top	4.7" wide X 1.75" high X 12.5" deep
Size, Rack Mount (-R)	19 inch standard chassis 1.75" high X 13.0" deep (Optional)
Power (std)	120 $\pm$ 10% VAC, 60Hz, 20 watts max., wall mount power supply
Model 2007C	No power supply, <b>Requires</b> 2001-01 Universal Power Supply, 100-240 $\pm$ 10% VAC, 60Hz, 20 watts max. <b>(not included)</b>

---

\*+10°C to +40°C; Specifications subject to change without notice

## 2.0 Installation

**2.1 Mechanical** - The 2007 is packaged in an aluminum extrusion. The 2007R is mounted on a 1 3/4" X 19" panel that can be mounted to a rack using the 4 holes at the ends. The 2007 and 2007R derive  $\pm 15V$  from a wall power supply. (See Figure 2.1.)

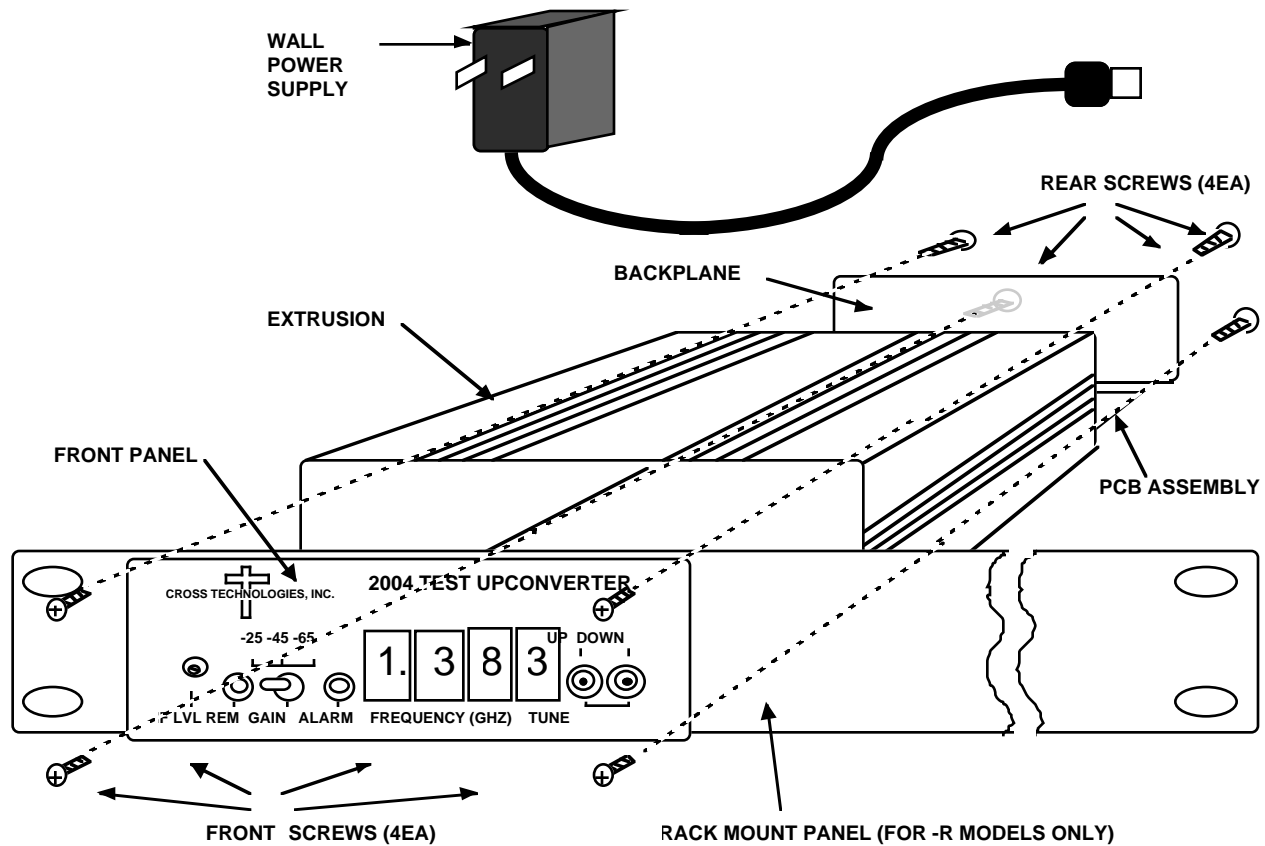

**FIGURE 2.1 SERIES 2000 ASSEMBLY DRAWING**

**2.2 Controls and Indicators** - Figure 2.2 shows front panel controls and indicators.

**2.3 Input / Output Signals** - Figure 2.3 shows the input and output signals to the 2007.

**2.4 Accessing and Changing On-Card Jumpers and Controls** - Figure 2.4 shows jumpers (with factory settings) and other on-card controls. To remove the printed circuit board (PCB) from the extrusion for access to the jumpers and controls:

- 1.) Remove four (4) **rear panel screws** (see Figure 2.1).
- 2.) **Gently** pull the back panel and PCB assembly completely out of the extrusion.
- 3.) With the **power supply disconnected**, move jumpers to the desired positions (Fig 2.4).
- 4.) **To set Preset levels** apply power via power supply and program levels (see Sec. 2.5.3).
- 5.) **Always remove power** when installing the PCB in to the extrusion. Make sure the shield goes in the lower channel and the PCB in the next channel above that in the extrusion.
- 6.) **Gently** push the back panel and PCB assembly completely in to the extrusion so the front panel controls go through the front panel.
- 7.) Install four (4) **rear panel screws**.

**DS1 - Remote LED** - Lights yellow when jumper JP9 is set to REMOTE. When this LED is on, SW1, SW3, and SW4 on the front panel are disabled and these functions are controlled remotely

**DS5 - Alarm LED** - Lights red when ambient temperature exceeds approximately 45 degrees C

**DS2, DS3, DS4 - Noise Level Displays** - Display the desired output noise level in C/No or dB below the maximum -50 dB-Hz level.

**SW2 - UP Noise Level Control Pushbutton Switch** - When in Continuous Noise Level mode (as set by jumper JP7), when pushed will increment noise level in 0.1 dB steps at about a 0.5 second rate. If held in for about 10 steps, will increment noise level in 0.1 dB steps at about a 0.05 second rate. When in Preset Noise Level mode (as set by jumper JP7), when pushed momentarily will display the preset level number it's on. If held in will increment preset level number and when released will display the noise level of the selected preset level.

**R48 - Noise Level Adjustment** - 10 turn potentiometer that adjusts the noise level by  $\pm 1.0$  dB for very small noise level adjustments to calibrate the 1599-10 to a specific level

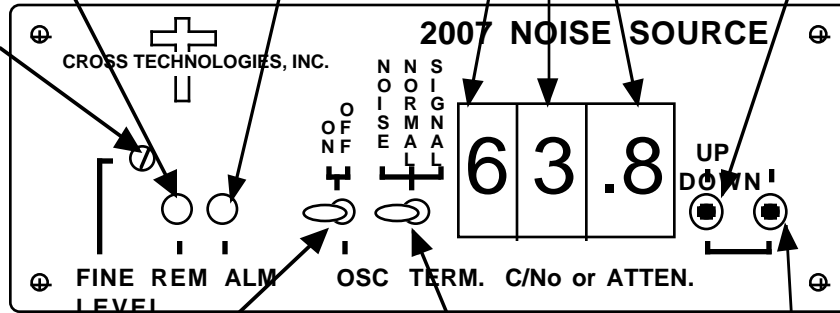

**SW4 - Test Carrier On/Off** - Turns -20.0 dBm, 70.0 MHz Test carrier on and off. This carrier is used as a reference to calibrate the desired carrier on a spectrum analyzer. This switch is disabled when in the REMOTE control mode.

**SW1 - Terminate Noise or Carrier** - Terminates noise or carrier for calibration purposes. This switch is disabled when in the REMOTE control mode.

**SW3 - DOWN Noise Level Control Pushbutton Switch** - Same as SW2 except decreases noise level or preset level. PUSHING SW2 and SW3 simultaneously displays the on-card temperature in degrees C (typically 5-7 degrees above ambient room temperature. An alarm condition occurs about 50 degrees)

**FIGURE 2.2 2007 Front Panel Controls and Indicators**

**J5 - -10dB Monitor** - 75Ω, BNC -10dB monitor of the 70 MHz signal plus noise output .

**J6 - 70MHz Signal + Noise OUT** - The signal plus noise output. This is a 75Ω, BNC output.

**J2 - DC IN** - The +15 VDC AND -15 VDC regulated DC voltage from the wall power supply

**J3 - REMOTE & MONITOR** - DB9 female connector

**PIN - FUNCTION**

- 1 - Ground
- 4,6, 7,8 - No Connection
- 3- Remote Control Data In - RS232C, 2400 B/s ASYNC (8N1) data from computer.
- 2- Remote Control Data Out - RS232C, 2400 B/s ASYNC (8N1) data to computer
- 5 - Ground
- 9 - Alarm FET open drain output - Provides a short to ground (100 ma max.) if a temperature alarm occurs.

**J4 - 70 MHz IF Input** - 75Ω, BNC 70 MHz input . Input must be at -20.0 dBm for a calibrated C/No reading.

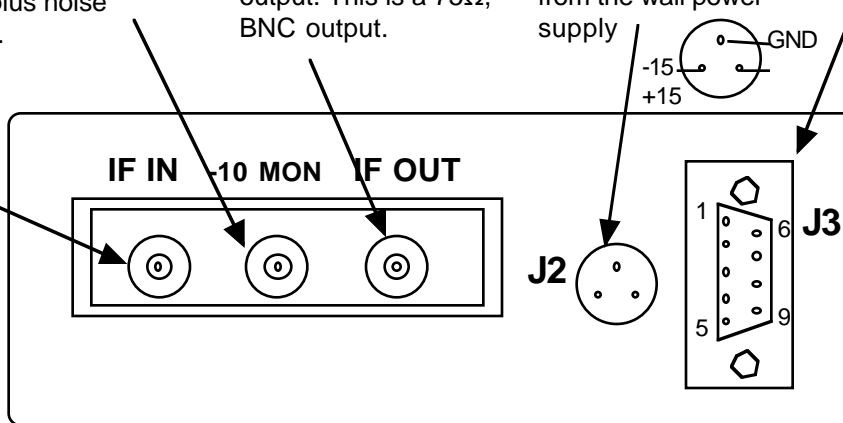

**FIGURE 2.3 2007 Inputs and Outputs**

## 2.5 Installation / Operation -

### 2.5.1 Local Operation -

- 1.) If required, check that on-card jumpers are set to the desired positions (Figure 2.4)
- 2.) Connect the wall power supply to the 2007 and the wall power supply to 115 VAC, 60 Hz (Figure 2.1)
- 3.) Connect a -20.0 dBm 70 MHz signal to 70 MHz SIGNAL IN (Figure 2.1, Figure 2.3)
- 4.) Set the desired noise level by pushing SW2 or SW3. If numbers 0 to 9 appear when pushing SW2 or SW3, the 2007 is set for the preset level mode (with on-card jumper JP7, Figure 2.4).  
See section 2.5.2 for noise level setting information.
- 5.) Be sure DS1 and DS5 are off (Figure 2.2).
- 8.) If needed, R48 can be adjusted (Figure 2.2) to SLIGHTLY adjust the noise level.

**Note that this uncalibrates the 2007 from its factory calibration.**

JUMPER	DESCRIPTION				
JP #	Description	Dot	Non-dot	Normal	COMMENTS
JP1	TEST-SWEEP IN	TEST	OPERATE	NON	FOR TEST ONLY
JP2	FILTER SELECT	10 MHz	40MHz	DOT	SELECTS BAND LIMITING 70MHz FILTER
JP3	FILTER SELECT	10 MHz	40MHz	DOT	SELECTS BAND LIMITING 70MHz FILTER
JP4	TEST-WDOG	TEST	ENABLE	NON	FOR TEST ONLY
JP5	ATTN/C/No SELECT	ATTN	C/No	NON	DISPLAY READS C/No OR ATTN FROM MAX NOISE LEVEL
JP6	ALARM ENABLE	ENABLE	DISABLE	DOT	ALLOWS ALARM TO BE DISABLED
JP7	PRESET/CONT. LEVEL	PRESET	CONT.	NON	NOISE ADJUSTMENT CONTINUOUS OR 1 OF 10 PRESET LEVELS
JP8	FILTER SELECT	10 MHz	40MHz	DOT	SELECTS BAND LIMITING 70MHz FILTER
JP9	REMOTE/LOCAL	LOCAL	REMOTE	DOT	SELECTS REMOTE OR LOCAL OPERATION
JP10	TEST-CAL/OPERATE	OPERATE	CALIBRATE	DOT	FOR TEST ONLY

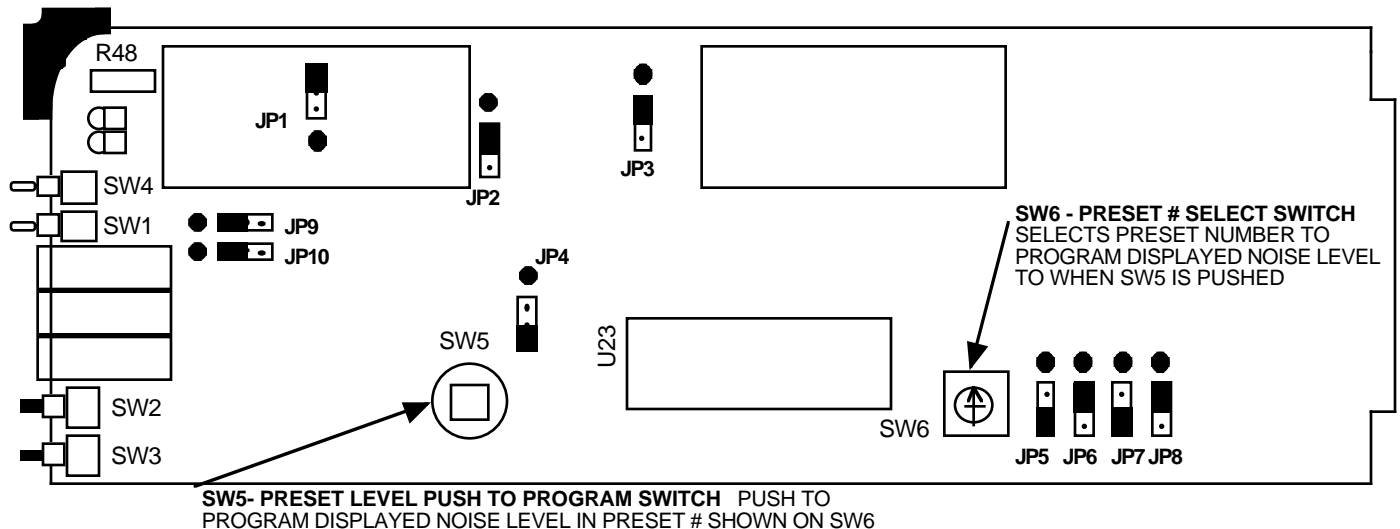

**FIGURE 2.4 2007 On-Card Jumpers and Controls**

**2.5.2 Noise Level Setting, Continuous Level Mode** - In this mode, the noise level is selected by pushing the up and down switches (SW2, SW3) on the front panel until the desired noise level is indicated on the front on the display. The noise level displayed is either C/No based on a -20.0 dBm carrier input or attenuation from the maximum 50 dB-Hz C/No noise level. Note that in the 40 MHz filter setting, the maximum allowable noise level corresponds to a 60 dB-Hz C/No and setting the the noise level higher causes the display to blink indicating an abnormal condition. EEROM U20 stores the last noise level set so in the event of power failure the 2007 will go to the noise level it was set to prior to the power outage. The front panel noise level setting switches increment or decrement the noise level in 0.1 dB steps at approximately a 0.5 second rate. If the switch remains depressed for approximately ten steps, the rate increases by a factor of ten.

**2.5.3 Noise Level Setting, Preset Level Mode** - Preset level selection is accomplished when the on board, but not front panel accessible, three-pin jumper (JP7) (Figure 2.4) is set to the “preset level” (DOT) position. Ten preset levels (0-9) can be selected as follows:

1. Remove the 2007 PCB (see section 2.4) to access the preset level selecting decimal switch (SW6) and the push to program switch (SW5) (Figure 2.4). With the display mode jumper (JP7) set in the noise level mode, the noise level set switches (SW2, SW3) are pushed to the noise level desired (Figure 2.2).
2. The decimal switch (SW6) is set to the preset level number desired to be programmed (Figure 2.4).
3. The programming button (SW5) is pushed to program the currently displayed noise level into that preset level number (Figure 2.4).
4. The above steps are repeated for any additional preset levels that are desired to be programmed.

At the factory, preset levels zero through nine are programmed for C/No from 60 to 70 dB-Hz in 1.0 dB steps. When in the remote mode, noise level setting by either continuous or preset level numbers can be provided, but programming of the preset levels can only be done locally. The noise level display (DS2, DS3, DS4) in the preset level mode displays the current preset level number selected when SW2 or SW3 is pushed, and, if the switch is held for more than 2 seconds, the preset level numbers are incremented or decremented depending on which button is pushed. The display indicates zero through nine for preset level number, and, when the desired preset level is selected and the button is released for one to two seconds, the noise level of that preset level is shown on the noise level display and this noise level display remains until switch SW2 or SW3 is pushed again.

**2.5.4 Selecting Filter Bandwidths** - Filter noise bandwidths of 10 MHz or 40 MHz can be selected by positioning jumpers JP2, JP3, and JP8 to DOT (10 MHz) or NON-DOT (40 MHz). The noise power level range for the 10 MHz position provides for a C/No of 50 dB-Hz to 90 dB-Hz with a -20.0 dBm input carrier and the 40 MHz position provides for a C/No of 60 dB-Hz to 90 dB-Hz with a -20.0 dBm input carrier. The 40 MHz bandwidth allows noise levels greater than 60 dB-Hz but this will cause the C/No display to blink indicating an abnormal condition and the likelihood of non linearity due to possible gain compression.

**2.5.5 Remote Operation** - Noise level (either continuous or preset noise levels), test carrier on/off, and termination of carrier or noise can be remotely commanded from an external (not supplied) PC using a simple DOS program. To place the 2007 in the Remote mode, place on-card jumper JP9 in the NON-DOT position

(Figure 2.4) and observe yellow LED DS1 (Figure 2.2) is on. Serial ASYNC (8N1) data is received via RS232C receiver U21 and sent via RS232C transmitter U38 at a 2.4 kB/s data rate. When in the remote mode, either continuous or preset noise levels can be adjusted, but programming of the preset levels can only be done locally. The 2007 noise power settings can be automatically calibrated with an HP3708A Noise Test Set. Contact Cross Technologies, Inc. (770-886-8005) for details.

**2.5.6 Remote Control DOS Program** - The 2007 remote control program (RemoteN.EXE) runs on an IBM compatible computer under DOS. (If you plan to operate in the remote mode using this program please contact Cross Technologies, Inc. (770-886-8005) and request a disk containing this program.) The user is prompted to select one of four possible functions, which are:

1. Set Noise Level
2. Set Preset Level Number
3. Test Carrier On/Off
4. Terminate Carrier or Noise

When Set Noise Level is selected, the up arrow and down arrow keys are used to increase or decrease the 2007's output noise level in 0.1 dB increments.

When Set Preset Level Number is selected, the up arrow and down arrow keys are used to select one of ten possible preset noise levels. The noise level of each preset level must be programmed locally, as described in the 2007 instruction manual.

When Test Carrier On/Off is selected, the up arrow and down arrow keys are used to select On or Off.

When Terminate Carrier or Noise is selected, the up arrow and down arrow keys are used to select Terminate Noise, Operate or Terminate Carrier.

The remote control program sends commands to the 2007 through pin 3 of the DB9 connector, J3 (Figure 2.3). Pin 3 is an RS-232 serial port set to accept 8N1 formatted data. Each command sent to the 2007 consists of an instruction byte followed by one or two bytes of data. The 2007 acknowledges receiving and successfully executing each remote control command by sending an **acknowledge byte** (2400 baud, 8N1 format) through pin 2 of the DB9 connector, J3.

**The instruction byte to set output noise level** is AA (hex). This byte must be followed by two data bytes of the desired noise level in BCD format. The following list shows examples of this.

<u>Noise Level</u>	<u>Control Bytes (Acknowledge byte = 06 (hex))</u>
50.0 dB/Hz	AA (hex), 05 (hex), 00 (hex)
50.1 dB/Hz	AA (hex), 05 (hex), 01 (hex)
90.0 dB/Hz	AA (hex), 09(hex), 00 (hex)

**The instruction byte to set preset noise levels** is AB (hex). This byte must be followed by a data byte that selects one of 10 preset noise levels. The following list shows examples of this.

<u>Preset Level #</u>	<u>Control Bytes (Acknowledge byte = 07 (hex))</u>
0	AB (hex), 00 (hex)
1	AB (hex), 01 (hex)
.	.
.	.
9	AB(hex), 09 (hex)

**The instruction byte to turn the test carrier on and off** is AC(hex). This byte must be followed by a data byte as follows:

<u>Test Carrier Condition</u>	<u>Control Bytes (Acknowledge byte = 08 (hex))</u>
Carrier On	AC (hex), 01 (hex)
Carrier Off	AC (hex), 02 (hex)

**The instruction byte to terminate carrier or noise** is AD(hex). This byte must be followed by a data byte as follows:

<u>Test Carrier Condition</u>	<u>Control Bytes (Acknowledge byte = 09 (hex))</u>
Terminate Noise	AD (hex), 01 (hex)
Operate	AD (hex), 02 (hex)
Terminate Carrier	AD (hex), 03 (hex)

## 3.0 Circuit Description

**3.1 Block Diagram Description - 2007 (Figure 3.1)** - Broadband noise is generated by noise diode CR1 followed by various amplifiers (U1, U3, U6, U8 with 21 dB gain; U15 with 13 dB Gain), a 200 MHz low pass filter (L16, C58, C62), 70 MHz bandpass filters (10 MHz consists of L3 - L6 and associated parts; 40 MHz consists of L18 - L 21 and associated parts), voltage controlled attenuators (U3, U7, U14), and a noise termination switch (U5) before being summed with the external signal by a resistive summing network (R43, R44, R38). The input signal goes through a variable attenuator (R42) for precise unity gain to the output, signal termination switch (U11), and buffer amplifier U13 before being summed with the noise by resistive summing network, R43, R44, R38. The combined signal plus noise goes to output amplifier U9 and output monitor amplifier U10. Controller U23 and associated circuitry provide attenuation commands to the attenuator D/A U17 and the noise diode bias D/A U16 which provides 0.1 dB steps and slight temperature compensation as needed to maintain the noise power accuracy over temperature as specified.

Commands for the D/A's, noise termination switch, signal termination switch, and test oscillator switches are provided from microprocessor U23 which receives serial RS232C commands from an external (not supplied) PC via RS232C receiver IC, U21. Microprocessor U23 can send serial RS232C commands to an external PC via RS232C transmitter IC, U38. Noise level (either continuous or preset noise levels), test carrier on/off, and termination of carrier or noise can be remotely commanded from an external (not supplied) PC using a simple DOS program.

Microprocessor U23 uses its internal oscillator controlled by the 3.6864 MHz crystal Y2. U19 is a watch dog timer for microprocessor U23. IC's U30, U31, U32, U27, U28, U29 provide multiplexing and strobing of displays DS2, DS3, DS4.

### **3.2 Controller Operation for 2007 Noise Source**

**3.2.1 General** - The controller consists of a microprocessor and associated circuitry which receives inputs from

- a) the front panel noise level set switches (SW2, SW3),
- b) the front panel terminate noise/carrier switch (SW1),
- c) the front panel test carrier switch (SW4),
- d) the on card display mode jumper (JP7),
- e) the on card preset level programming decimal switch (SW6),
- f) the on card preset level programming "push to program" switch (SW5),
- g) the on card local / remote control mode jumper (JP9), and
- h) the on temperature detector IC (U35)

**The controller provides command signals to the:**

- a) noise level D/A's (U16, U17),
- b) carrier, noise terminating switches (U5, U11),
- c) test carrier enable switch (Q2), and
- d) the front panel noise level display (DS2, DS3, DS4).

In addition, when in the remote control mode, the microprocessor U23 accepts a serial data stream which is generated by a simple DOS program (by an external, not provided, PC) that selects the noise level and the output level. Serial data is received via RS232C receiver U4 and sent via RS232C transmitter U38. The following provides additional detail.

**3.2.2 Noise Level Setting, Continuous Level Mode** - In this mode, the noise level is selected by pushing the up and down switches (SW2, SW3) on the front panel until the desired noise level is indicated on the front on the display. The noise level displayed is either C/No based on a -20.0 dBm carrier input or attenuation from the maximum 50 dB-Hz C/No noise level. Note that in the 40 MHz filter setting, the maximum allowable noise level corresponds to a 60 dB-Hz C/No and setting the noise level higher causes the display to blink indicating an abnormal condition. EEROM U20 stores the last noise level set so in the event of power failure the 2007 will go to the noise level it was set to prior to the power outage. The front panel noise level setting switches increment or decrement the noise level in 0.1 dB steps at approximately a 0.5 second rate. If the switch remains depressed for approximately ten steps, the rate increases by a factor of ten.

**3.2.3 Noise Level Setting, Preset Level Mode** - Preset level selection is accomplished when the on board, but not front panel accessible, three-pin jumper (JP7) (Figure 2.4) is set to the “preset level” (DOT) position. Ten preset levels (0-9) can be selected as follows:

1. The 2007 is placed on an extender card to access the preset level selecting decimal switch (SW6) and the push to program switch (SW5) (Figure 2.4). With the display mode jumper (JP7) set in the noise level mode, the noise level set switches (SW2, SW3) are pushed to the noise level desired (Figure 2.2).
2. The decimal switch (SW6) is set to the preset level number desired to be programmed (Figure 2.4).
3. The programming button (SW5) is pushed to program the currently displayed noise level into that preset level number (Figure 2.4).
4. The above steps are repeated for any additional preset levels that are desired to be programmed.

At the factory, preset levels zero through nine are programmed for C/No from 60 to 70 dB-Hz in 1.0 dB steps. When in the remote mode, noise level setting by either continuous or preset level numbers can be provided, but programming of the preset levels can only be done locally. The noise level display (DS2, DS3, DS4) in the preset level mode displays the current preset level number selected when SW2 or SW3 is pushed, and, if the switch is held for more than 2 seconds, the preset level numbers are incremented or decremented depending on which button is pushed. The display indicates zero through nine for preset level number, and, when the desired preset level is selected and the button is released for one to two seconds, the noise level of that preset level is shown on the noise level display and this noise level display remains until switch SW2 or SW3 is pushed again.

**3.2.4 Selecting Filter Bandwidths** - Filter noise bandwidths of 10 MHz or 40 MHz can be selected by positioning jumpers JP2, JP3, and JP8 to DOT (10 MHz) or NON-DOT (40 MHz). The noise power level range for the 10 MHz position provides for a C/No of 50 dB-Hz to 90 dB-Hz with a -20.0 dBm input carrier and the 40 MHz position provides for a C/No of 60 dB-Hz to 90 dB-Hz with a -20.0 dBm input carrier. The 40 MHz bandwidth allows noise levels greater than 60 dB-Hz but this will cause the C/No display to blink indicating an abnormal condition and the likelihood of non linearity due to possible gain compression.

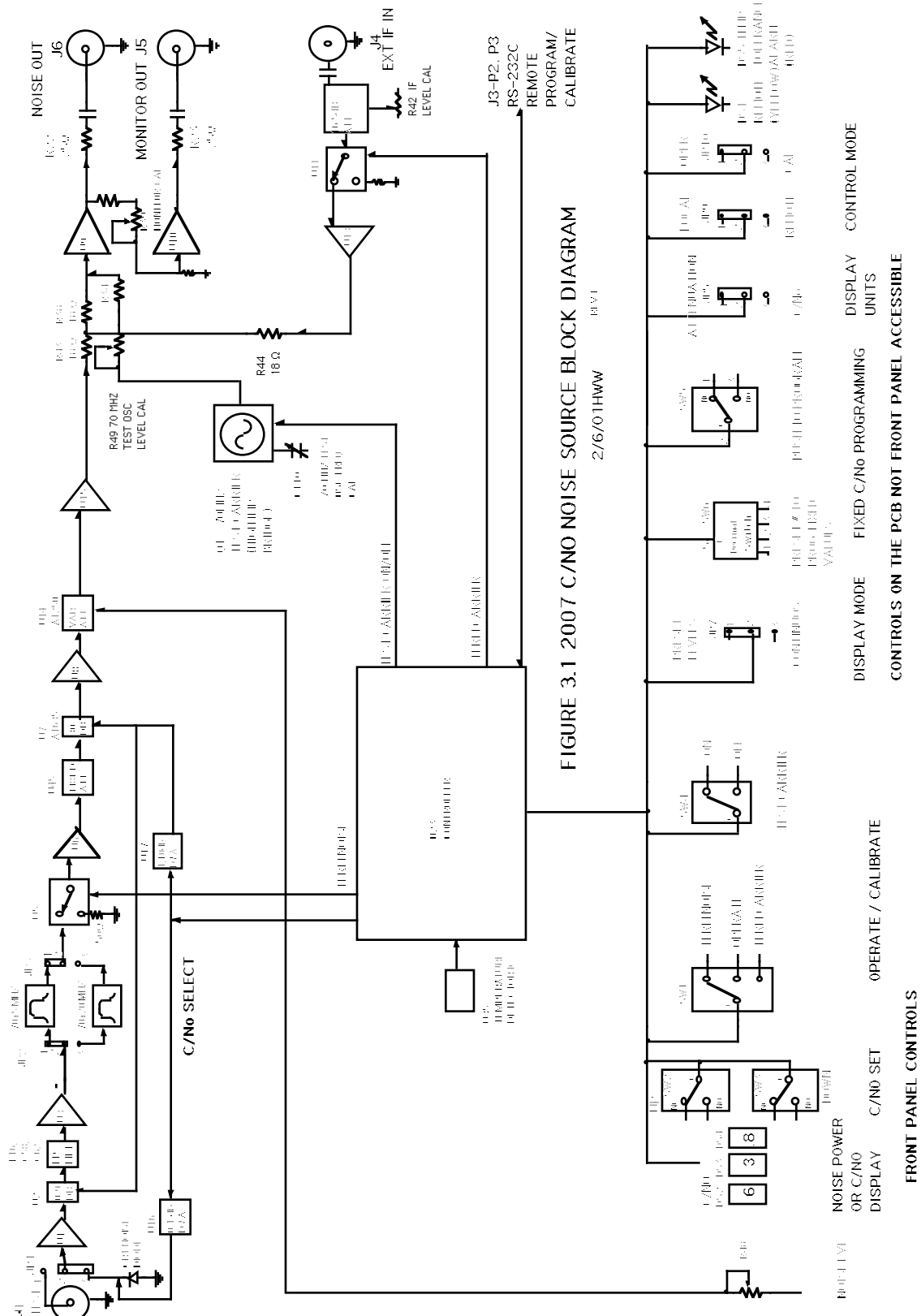

FIGURE 3.1 2007 C/NO NOISE SOURCE BLOCK DIAGRAM

2/6/01HW

#### 4.0 Environmental Use Information

- A. **Rack-Mounting** - To mount this equipment in a rack, please refer to the installation instructions located in the user manual furnished by the manufacturer of your equipment rack.
- B. **Mechanical Loading** - Mounting of equipment in a rack should be such that a hazardous condition does not exist due to uneven weight distribution.
- C. **Elevated Operating Ambient Temperature** - If installed in a closed or multiunit rack assembly, the operating ambient temperature of the rack may be greater than room ambient temperature. Therefore, consideration should be given to Tmra.
- D. **Reduced Air Flow** - Installation of the equipment in a rack should be such that the amount of air flow required for safe operation of the equipment is not compromised. Additional space between unit may be required.
- E. **Circuit Overloading** - Consideration should be given to the connection of the equipment to the supply circuit and the effect that overloading of circuits could have on over current protection and supply wiring. Appropriate consideration of equipment name plate rating should be used, when addressing this concern.
- F. **Reliable Earthing** - Reliable earthing of rack-mounted equipment should be maintained. Particular attention should be given to supply connections other than direct connection to the Branch (use of power strips).
- G. **Top Cover** - There are no serviceable parts inside the product so, the Top Cover should not be removed. If the Top Cover is removed the ground strap and associated screw **MUST BE REINSTALLED** prior to Top Cover screw replacement. **FAILURE TO DO** this may cause **INGRESS** and/or **EGRESS** emission problems.



6170 Shiloh Road  
Alpharetta, Georgia 30005

(770) 886-8005  
FAX (770) 886-7964  
Toll Free 888-900-5588

WEB [www.crosstechnologies.com](http://www.crosstechnologies.com)  
E-MAIL [info@crosstechnologies.com](mailto:info@crosstechnologies.com)

Printed in USA