

Instruction Manual

Models 2006-11/-11P/-12/-12P Test Upconverters

January 2009 Rev A

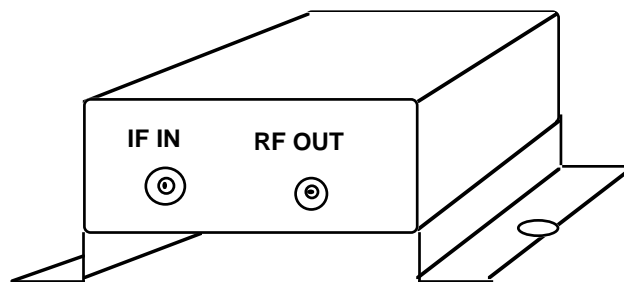

Data, drawings, and other material contained herein are proprietary to Cross Technologies, Inc., but may be reproduced or duplicated without the prior permission of Cross Technologies, Inc. for purposes of operating the equipment.

When ordering parts from Cross Technologies, Inc., be sure to include the equipment model number, equipment serial number, and a description of the part.



6170 Shiloh Road
Alpharetta, Georgia 30005

(770) 886-8005
FAX (770) 886-7964
Toll Free 888-900-5588

WEB www.crosstechnologies.com

E-MAIL info@crosstechnologies.com

INSTRUCTION MANUAL

MODELS 2006-11,12 Test Upconverters

<u>TABLE OF CONTENTS</u>	<u>PAGE</u>
Warranty	2
1.0 General	3
1.1 Equipment Description	3
1.2 Technical Characteristics	4
2.0 Installation	5
2.1 Mechanical	5
2.2 Controls and Indicators	5
2.3 Inputs / Outputs Signals	5
2.4 Installation/Operation	7
2.4.1 Installing and Operating the 2006	7
2.4.2 LO and IF for the 2006-11, -12	8
3.0 Circuit Description	8
3.1 Block Diagram Description	8
4.0 Compliance Section	9
4.1 Use Information	10

WARRANTY - The following warranty applies to all Cross Technologies, Inc. products.

All Cross Technologies, Inc. products are warranted against defective materials and workmanship for a period of one year after shipment to customer. Cross Technologies, Inc.'s obligation under this warranty is limited to repairing or, at Cross Technologies, Inc.'s option, replacing parts, subassemblies, or entire assemblies. Cross Technologies, Inc. shall not be liable for any special, indirect, or consequential damages. This warranty does not cover parts or equipment which have been subject to misuse, negligence, or accident by the customer during use. All shipping costs for warranty repairs will be prepaid by the customer. There are not other warranties, express or implied, except as stated herein.



6170 Shiloh Road
Alpharetta, Georgia 30005

(770) 886-8005
FAX (770) 886-7964
Toll Free 888-900-5588

WEB www.crosstechnologies.com
E-MAIL info@crosstechnologies.com

2006-11, -11P, -12, -12P TEST UP CONVERTERS

SECTION 1 GENERAL

1.1 Equipment Description-

The **2006-11** converts 70 MHz to 1200 MHz (Ku) and 1060 MHz (C) or 140 MHz to 1270 MHz (Ku) and 990 MHz (C).

The **2006-12** converts a 70 or 140 MHz IF signal to frequencies determined by a customer specified LO from 1020 to 1520 MHz.

The IF input goes to the gain selection switch (-5 or -25 dB gain), an amplifier, and is mixed with a 1130 MHz local oscillator (LO) signal for the 2006-11 and a customer specified LO from 1020 to 1520 MHz for the 2006-12. The 2006-12's frequency can be changed by replacing the controller IC. The mixer output goes to the output attenuator. A green LED indicates the presence of DC power. Power is provided by the LNB voltage from the receiver under test and connectors are BNC female for the 70 MHz input and F, female for the RF output. The **2006-11P** and **2006-12P** are powered by a wall mount power supply.

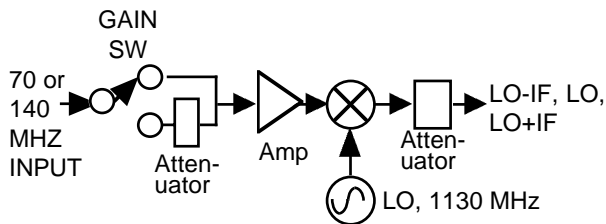

2006-11 Test Upconverter Block Diagram

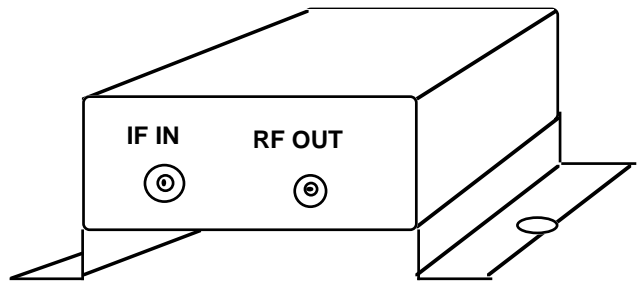

2006 Test Upconverter

1.2 Technical Characteristics

TABLE 1.0 2006-11, -12 UPCONVERTER SPECIFICATIONS*

Input Characteristics	<u>2006-11, -12</u>
Input Impedance/RL	75 Ω /15 dB
Frequency	70 or 140 MHz center
Input Level, maximum	-10 dBm (low gain), -30 dBm (high gain)
Input 1dB/3RD ORDER	0 / +10 dBm (low gain), -20/-10 dBm (high gain)
Output Characteristics	
Impedance/RL	75 Ω /12 dB
Frequency , LO	1130 MHz (-11), 1020-1520 (-12) fixed
Frequency , OUTPUT	LO-IF, LO, LO+IF
Level, with -10 dBm in	-35 \pm 5 dBm, low gain,-15 \pm 5 dBm, high gain
Channel Characteristics	
Gain	-25 \pm 3 dBm, low gain,-5 \pm 3 dBm, high gain
Spurious Response	NA; output not filtered
Frequency Response	\pm 1 dB, over \pm 20 MHz; \pm 0.5 dB, any 10 MHz
Synthesizer Characteristics	
Frequency Accuracy	\pm 25 kHz max
Phase Noise, Suitable for;	64 kB/s QPSK,1/2 FEC
Frequency Selection	NONE: Fixed tuned
DC Power	Green LED
Other	
RF, IF Connectors	F, female, BNC, female
Size (W x H x D)	3.3 x 1.2 x 4.0 (in.); 83.8 x 30.5 x 101.6 (mm)
Power	+14 to +20 VDC, 150 ma on RF In; +15 VDC, 150 ma on DCPWR IN (-P)
RF Connections	Installation Category I
Main Supply	Installation Category II

*+10 to +40 degrees C; 2000 meters max elevation; 80% max humidity; Pollution Degree 2;

Specifications subject to change without notice.

2.0 Installation

2.1 Mechanical - The 2006-11, -12 are packaged in an aluminum chassis. The unit can be mounted to a panel using the 2 holes at the bottom side flange. The unit derives +DC (+14 to +20 VDC) from the RF out center conductor or +15 VDC from a wall mount power supply for the -P models. (See Figure 2.1 and Figure 2.2).

2.1.1 Cleaning Instructions - Wipe the exterior with a dry, soft cloth. Use no detergent or cleaning chemicals.

2.2 Controls and Indicators - There are no controls. A green LED indicates presence of DC power (Figure 2.3).

2.3 Input / Output Signals - Figure 2.3 shows the input and output signals to the 2006-11, -12.

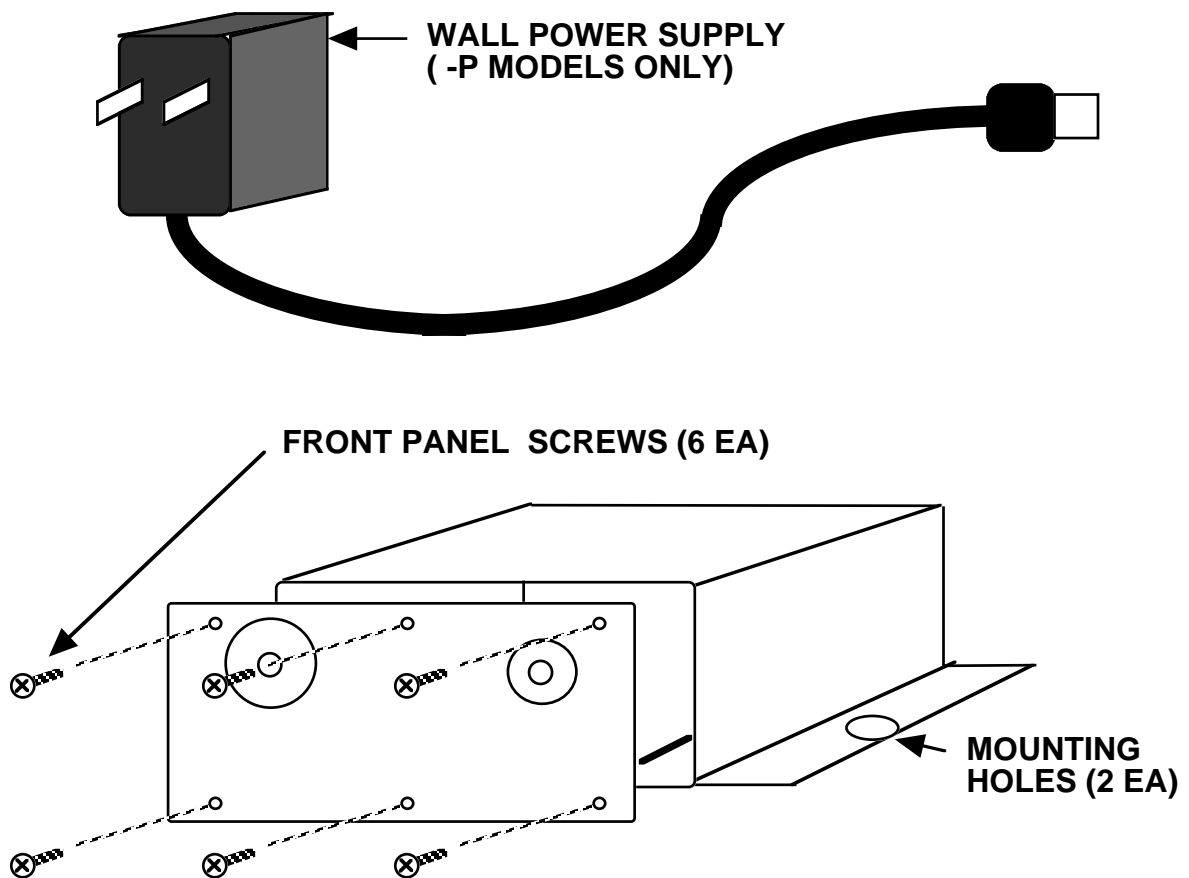

FIGURE 2.1 2006-11, -12 ASSEMBLY DRAWING

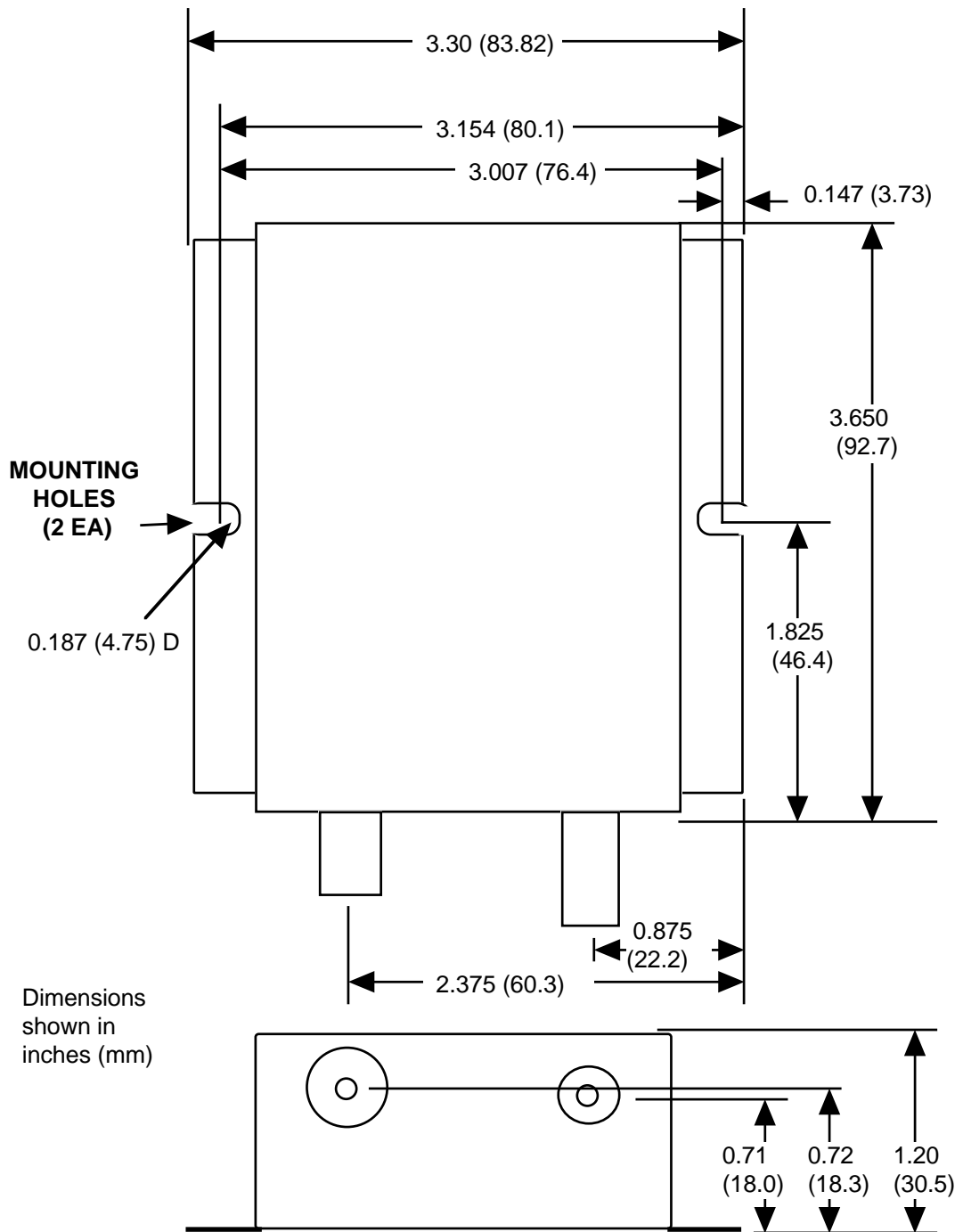

Figure 2.2 2006-1X, -2X Package Dimensions

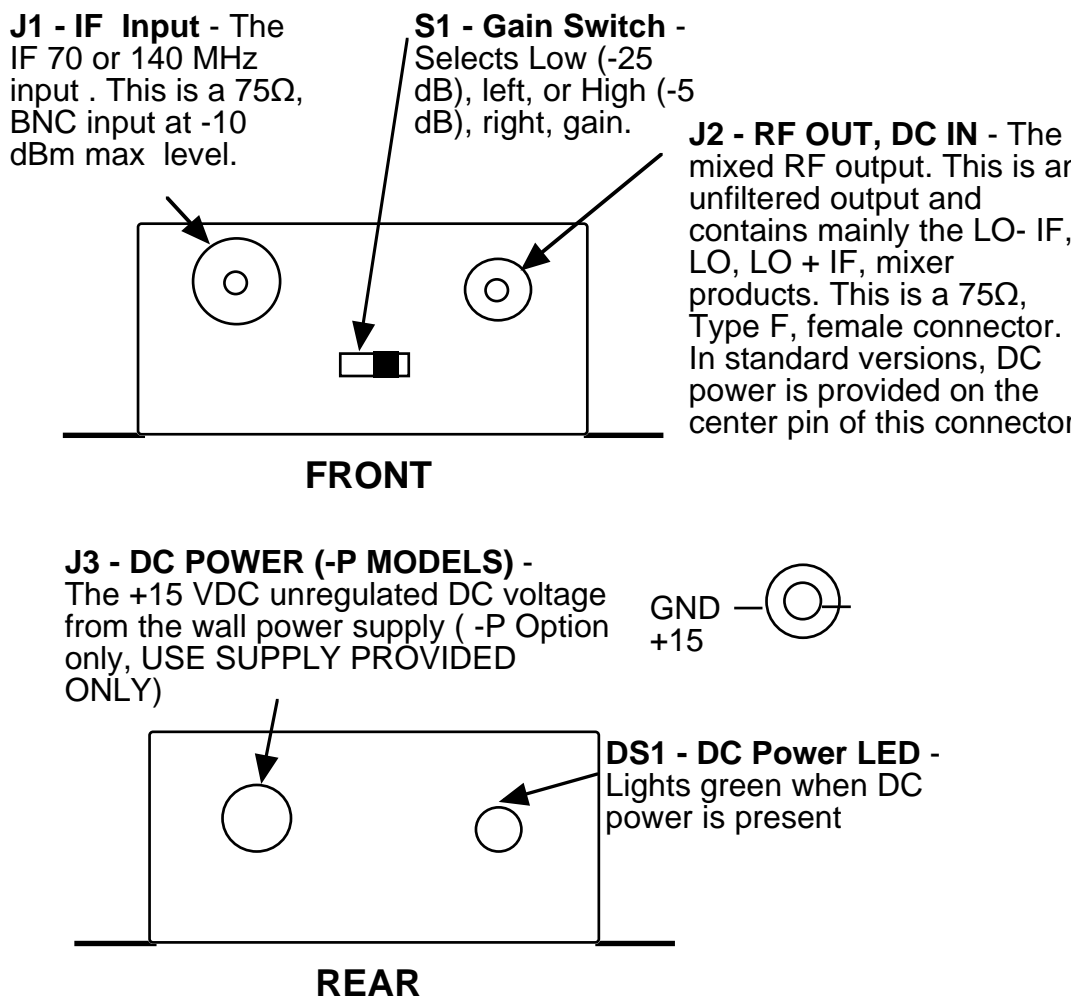

Figure 2.3 2006-11, -12 Input, Output, Power LED, External DC In (-P Option)

2.4 Installation / Operation -

2.4.1 Installing and Operating the 2006-11, -12 -

- 1.) Secure the 2006-11, -12 to a panel using the two bottom mounting holes (see Figure 2.1 and Figure 2.2)
- 2.) Be sure the receiver LNB voltage to power the 2006-11, -12, is +14 to +20 VDC on the RF center conductor. The -P models receive unregulated +15 VDC from a wall power supply provided.
- 3.) Observe that green power LED (DS1) is illuminated.
- 4.) Select High (-5 dB) or Low (-25 dB) Gain with S1.
- 5.) Connect -10 dBm (max., Low Gain) or -30 dBm (max., High Gain) signal to IF In, J1 (Figure 2.3)
- 6.) Connect the RF OUT, J2, to the receiver under test

2.4.2 - LO and IF for the 2006-11, -12 - The **2006-11** has a fixed LO of 1130 MHz with output frequencies of 1060 MHz (C-band, high side LO) and 1200 MHz (Ku-band, low side LO) with a 70 MHz IF and output frequencies of 990 MHz (C-band, high side LO) and 1270 MHz (Ku-band, low side LO) with a 140 MHz IF. The **2006-12** LO is customer specified from 1020 to 1520 MHz as noted on the top decal and has a LO-IF, LO, and LO+IF output.

3.0 Circuit Description

3.1 Block Diagram Description - 2006-11, -12 (Figure 3.1) - The 70 or 140 MHz input goes to a capacitor and then to a switch which selects -5 or -25 dB gain. The signal then goes via an amplifier to a mixer which receives the LO generated by the VCO and provides the LO \pm IF and LO unfiltered output. This signal next goes to an attenuator and a 50 to 75 ohm output matching pad. Commands for the phase lock loop IC are provided serially from the microcontroller which determines the frequency of the LO. A 25 MHz crystal provides the reference frequency for the synthesizer IC.

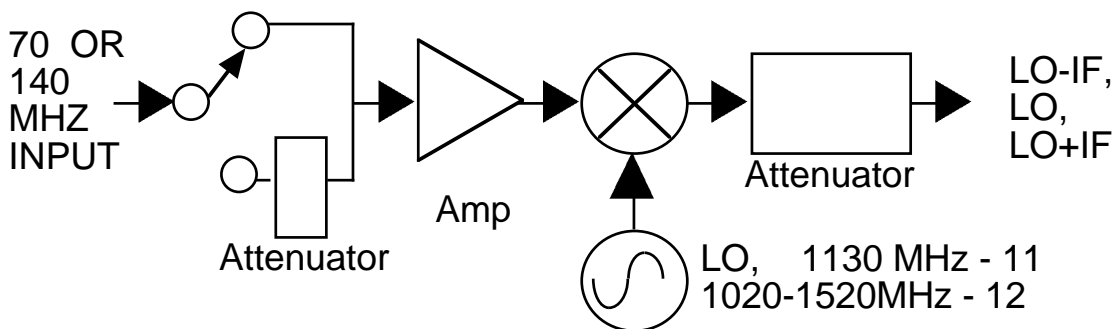

FIGURE 3.1 BLOCK DIAGRAM

4.0 Compliance Section

4.1 FCC Compliance Statement

This device complies with Part 15 of the FCC Rules. Operation is subject to the following two conditions: (1) This device may not cause harmful interference, and (2) this device must accept any interference received, including interference that may cause undesired operation.

NOTE: This equipment has been tested and found to comply with the limits for a Class A digital device, pursuant to Part 15 of the FCC Rules. These limits are designed to provide reasonable protection against harmful interference when the equipment is operated in a commercial environment.

This equipment generates, uses, and can radiate radio frequency energy and, if not installed and used in accordance with the instruction manual, may cause harmful interference to radio communications. Operation of this equipment in a residential area is likely to cause harmful interference in which case the user will be required to correct the interference at his own expense.

INFORMATION TO USER

Caution: Changes or modifications not expressly approved by the party responsible for compliance could void the user's authority to operate the equipment.

SPECIAL ACCESSORIES

Cables to be used with this equipment must be 75 ohm RG59 or better in order to ensure compliance, and it is the responsibility of the user to provide and use those components and accessories.

4.2 Industry Canada Compliance Statement

This Class A digital apparatus complies with Canadian ICES-003.

Cet appareil numérique de la classe A est conforme à la norme NMB-003 Canada.

4.3 UL

This product has earned the UL Listing Mark for Canada and the United States.

4.4 Declaration of Conformity

EN DECLARATION OF CONFORMITY

Manufacturer -

CROSS TECHNOLOGIES INC.
6170 Shiloh Road
Alpharetta, Georgia 30005

Declares under our sole responsibility that the upconverters,
Models 2006-11, -12, -21, -22 and 2006-11P, -12P, -21P, -22P
to which this declaration relates are in conformity with the following standards or other normative documents.
EN61326-1: (2000) following the provisions of
EMC 89/336/EEC Directive in accordance with CE marking requirements and
EN61010-1:1993 +A2:1995 according to the general product safety directive 92/59/EEC.

CAUTION: To maintain regulatory compliance, use only the power supply provided with the product.
CROSS TECHNOLOGIES INC., 4/16/01

Heinz wegener, President



4.1 Use Information

- A. **Elevated operating ambient temperature** - if installed in a closed or multi-unit rack assembly, the operating ambient temperature of the rack may be greater than room ambient temperature. Therefore, consideration should be given to Tmra.
- B. **Reduced air flow** - Installation of the equipment in a rack should be such that the amount of air flow required for safe operation of the equipment is not compromised. Additional space between unit may be required.
- C. **Mechanical loading** - Mounting of equipment in a rack should be such that a hazardous condition does not exist due to uneven weight distribution.
- D. **Circuit Overloading** - Consideration should be given to the connection of the equipment to the supply circuit and the effect that overloading of circuits could have on over current protection and supply wiring. Appropriate consideration of equipment name plate rating should be used, when addressing this concern.
- E. **Reliable Earthing** - Reliable earthing of rack-mounted equipment should be maintained. Particular attention should be given to supply connections other than direct connection to the Branch (use of power strips).
- F. **Top Cover** - There are no servicable parts inside the product so, the Top Cover should not be removed. If the Top Cover is removed the ground strap and associated screw **MUST BE RE-INSTALLED** prior to Top Cover screw replacement. **FAILURE TO DO** this may cause **INGRESS** and/or **EGRESS** emission problems.



6170 Shiloh Road
Alpharetta, Georgia 30005

(770) 886-8005
FAX (770) 886-7964
Toll Free 888-900-5588

WEB www.crosstechnologies.com
E-MAIL info@crosstechnologies.com