

INSTRUCTION MANUAL

MODEL 2005-04 AGILE TEST UPCONVERTER

Data, drawings, and other material contained herein are proprietary to Cross Technologies, Inc., but may be reproduced or duplicated without the prior permission of Cross Technologies, Inc. as required for normal operation of the equipment.

When ordering parts from Cross Technologies, Inc., be sure to include the equipment model number, equipment serial number, and a description of the part.

First Edition, **April 2003, REV A 4/15/03**

**CROSS TECHNOLOGIES, INC.
6170 SHILOH ROAD
ALPHARETTA, GEORGIA 30005**

**(770) 886-8005
FAX (770) 886-7964**

**WEB www.crosstechnologies.com
E-MAIL info@crosstechnologies.com**

INSTRUCTION MANUAL

MODEL 2005-04 AGILE TEST UPCONVERTER

<u>TABLE OF CONTENTS</u>	<u>PAGE</u>
Warranty	2
1.0 General	3
1.1 Equipment Description	3
1.2 Technical Characteristics	3
2.0 Installation	4
2.1 Mechanical	4
2.1.1 Cleaning Instructions	4
2.2 Controls and Indicators	4
2.3 Input / Output Signals	4
2.4 Accessing the PC Card	4
2.5 Installation / Operation	5
2.5.1 Installing and Operating the 2005	5
2.5.2 Frequency Setting, SW1 to SW4	5
2.5.3 LO and IF for the 2005-04	6
2.5.4 Selecting LO and IF	6
2.5.5 Selecting Gain	6
3.0 Circuit Description	7
3.1 Block Diagram Description	7
3.2 Controller Operation for 2005	7
3.2.1 General	7
3.2.2 Frequency Setting, SW1 to SW4	7

WARRANTY - The following warranty applies to all Cross Technologies, Inc. products.

All Cross Technologies, Inc. products are warranted against defective materials and workmanship for a period of one year after shipment to customer. Cross Technologies, Inc.'s obligation under this warranty is limited to repairing or, at Cross Technologies, Inc.' option, replacing parts, subassemblies, or entire assemblies. Cross Technologies, Inc. shall not be liable for any special, indirect, or consequential damages. This warranty does not cover parts or equipment which have been subject to misuse, negligence, or accident by the customer during use. All shipping costs for warranty repairs will be prepaid by the customer. There are not other warranties, express or implied, except as stated herein.

**CROSS TECHNOLOGIES, INC.
6170 SHILOH ROAD
ALPHARETTA, GEORGIA 30005**

**(770) 886-8005
FAX (770) 886-7964**

**WEB www.crosstechnologies.com
E-MAIL info@crosstechnologies.com**

MODEL 2005-04 AGILE TEST UP CONVERTER

1.0 General

1.1 Equipment Description

The 2005 Test Upconverters loop 70 or 140 MHz modulators to L-band receivers. The 2005-04 takes a 70 MHz signal and converts it to 950 to 2050 MHz in 1 MHz steps with a high side 1020 to 2120 MHz LO (C). Over a limited frequency range, the 2005-04 also operates with a 140 MHz input (950 - 1980 MHz out with high side LO (C); 1160 - 2050 MHz out with low side LO (Ku)) and 70 MHz in with low side LO (Ku) (1090 - 2050 MHz out).

Featuring low phase noise, these units are used to loop 70 or 140 MHz modulators to L-band receivers in uplinks. The 70 or 140 MHz carrier input is mixed with a synthesized local oscillator (LO) signal. The output frequency is selected with four BCD switches which control the synthesized LO. Front panel LEDs light when DC power is applied (green) and when a PLL alarm occurs (red). The mixer output is applied to the output amplifier providing a nominal gain of -5 dB (high gain) or -25 dB (low gain). Power is provided by the LNB voltage from the receiver under test and connectors are BNC female for the 70 MHz input and F, female for the RF output. Optionally, the 2005 can be powered by an external wall mount power supply (**option -P or -C**). The 2005 can be mounted on an 1 3/4" X 19" rack mount panel (**option -R**).

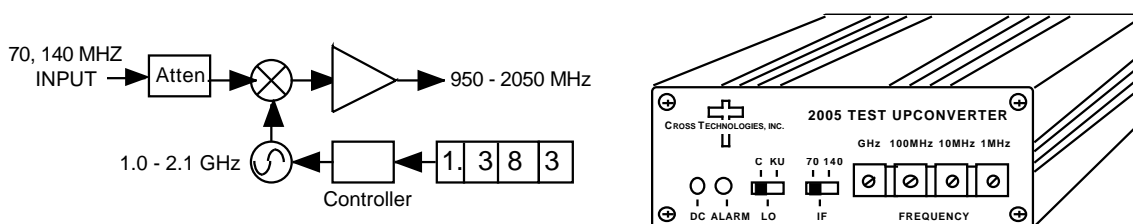

FIGURE 1.1 2005-04 Agile Test Upconverter Block Diagram and Chassis

1.2 Technical Characteristics

TABLE 1.0 2005-04 UP CONVERTER SPECIFICATIONS

Input Characteristics	
Input Impedance/RL	75 Ω /12 db
Frequency	70 or 140 MHz center
Input Level	-10 to -20 dBm
Input 1 dBcomp	0 dBm
Output Characteristics	
Impedance/RL	75 Ω /8 db
Frequency Band	950 -2050 MHz
Channel Characteristics	
Gain (at 1200 MHz)	-25 dB \pm 3 dB(low gain); -5 dB \pm 3 dB(high gain)
Spurious Response	NA; output not filtered
Frequency Response	\pm 4 dB, 950 -2050 MHz; \pm 0.5 dB, any 10 MHz increment
Synthesizer Characteristics	
Frequency Accuracy	\pm 25 kHz max
Frequency Step	1.0 MHz minimum
Phase Noise(dBC/Hz)	-80, 10 kHz; -90, 100 kHz; -100, 1 MHz
Controls	
Frequency Selection	direct readout BCD switches
Indicators	
DC Power; Alarm	Green LED; Red LED
Other	
RF, IF Connectors	F, female, BNC, female
Size, Bench Top	4.7" wide X 1.75" high X 6.5" deep
Size, Rack Mount (-R)	19 inch standard chassis 1.75"high X 7.0" deep (Optional)
Power	+14 to +20 VDC, 200 ma on RF In;
AC Power (-P, -C)	120 \pm 10% VAC, 60 Hz, 10 W max, wall power supply, +15VDC unregulated, 600ma
	(-P) wall power supply provided by Cross Technologies
	(-C) wall power supply provided by customer
RF Connections	Installation Category I
Main Supply	Installation Category II

*+10 to +40 degrees C; 2000 meters max elevation; 80% max humidity; Pollution Degree 2; Specifications subject to change without notice

2.0 Installation

2.1 Mechanical - The 2005 is packaged in an aluminum extrusion. The **-R option** is mounted on a 1 3/4" X 19" panel that can be mounted to a rack using the 4 holes at the ends. The unit derives +DC from the RF out center conductor (+14 to +24 VDC) or the wall power supply (**option -P, option -C**) (+15V unregulated). See Figure 2.1.

2.1.1 Cleaning Instructions - Wipe the exterior with a dry, soft cloth. Use no detergent or cleaning chemicals.

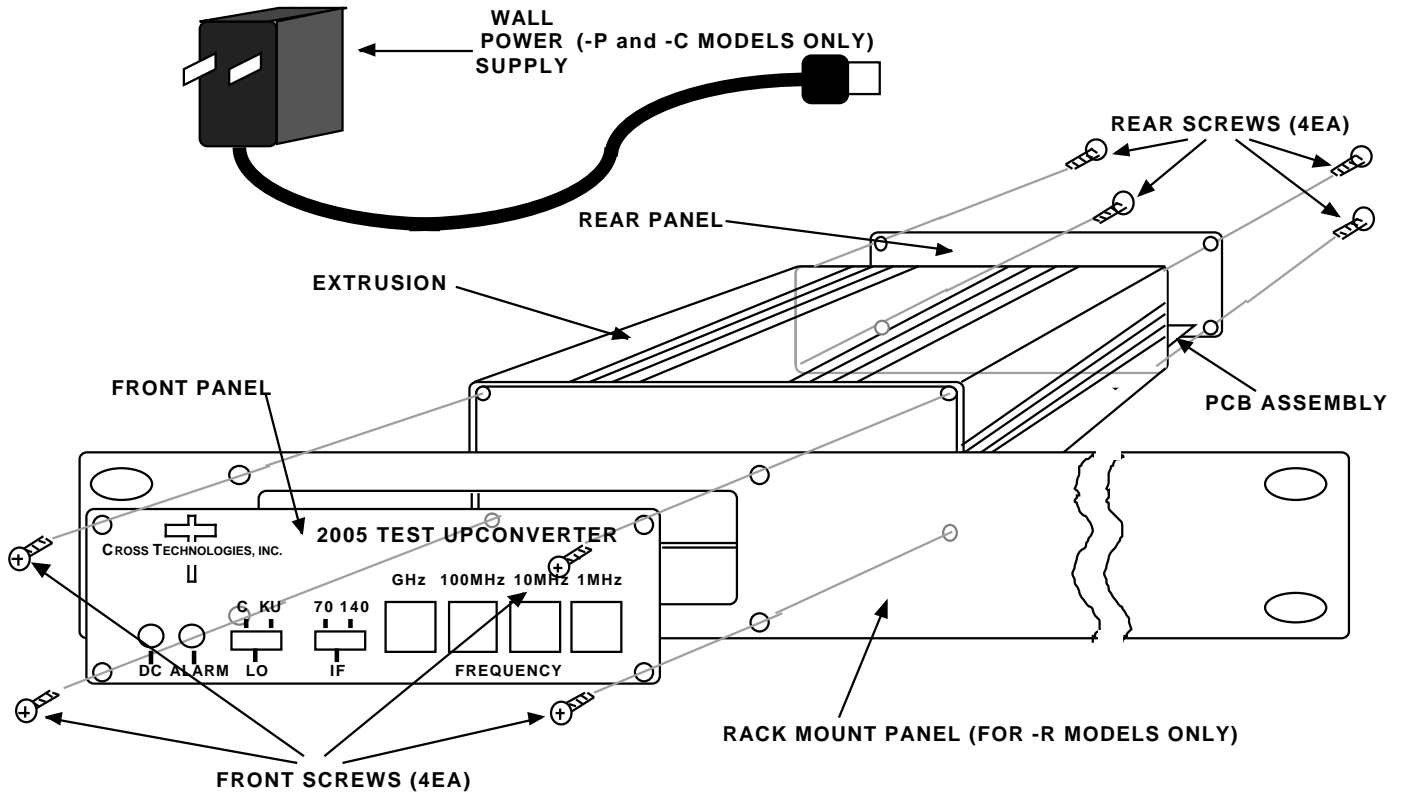

FIGURE 2.1 2005 Assembly Drawing

2.2 Controls and Indicators - Figure 2.2 shows front panel controls and indicators.

2.3 Input / Output Signals - Figure 2.3 shows the input and output signals to the 2005.

2.4 Accessing the PC Card - There are NO USER JUMPERS or other on-card controls. ALTHOUGH IT IS NOT RECOMMENDED AND MAY VOID THE WARRANTY the following shows how to remove the printed circuit board (PCB) from the extrusion:

- 1.) **Always remove power** when installing or removing the PCB from the extrusion
- 2.) Remove four (4) **rear panel screws** (see Figure 2.1).
- 3.) **Gently** pull the rear panel and PCB assembly completely out of the extrusion.
- 4.) To install the PCB **gently** push the rear panel and PCB assembly completely into the extrusion. Make sure the shield goes in the lower channel and the PCB in the next channel above that in the extrusion and that the front panel controls go through the front panel holes.
- 5.) Install four (4) **rear panel screws**.

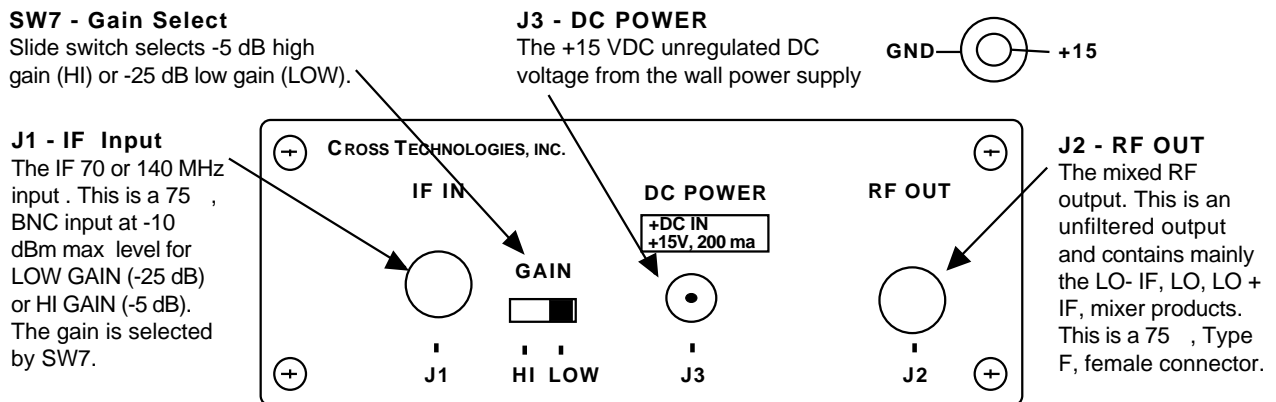
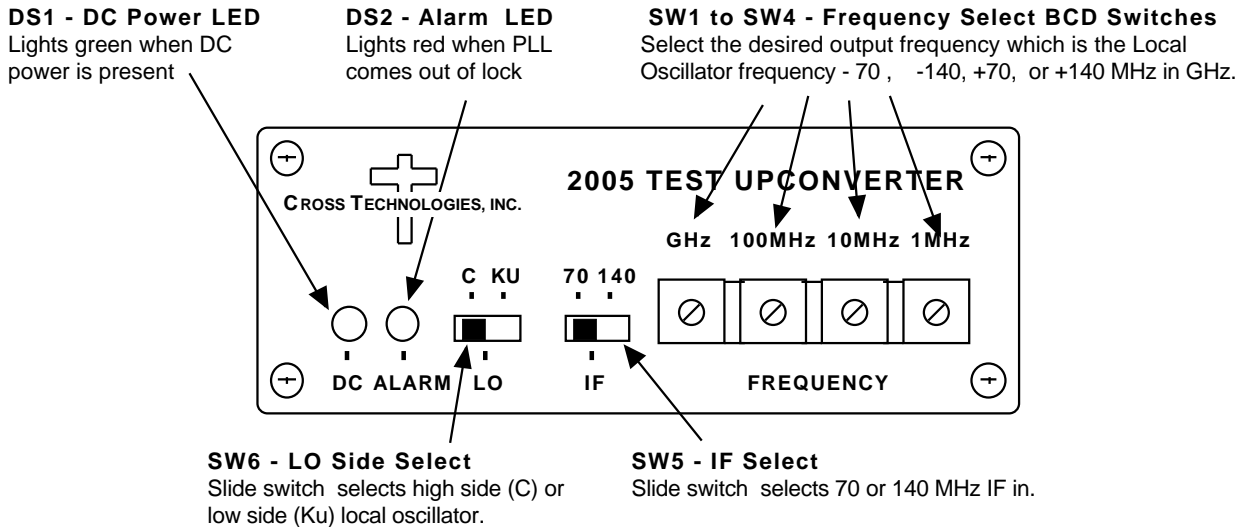

2.5 Installation / Operation

2.5.1 Installing and Operating the 2005

- 1.) Check that SW5, SW6, SW7 are set to the desired positions (Figure 2.2, Figure 2.3)
- 2.) If using the receiver LNB voltage to power the 2005, be sure +14 to +24 VDC is on the RF center conductor.
- 3.) If using the wall power supply, connect it to the 2005 and the wall power supply to 115 VAC, 60 Hz (Figure 2.1)
- 4.) Connect a -10dBm (max.) signal to IF In, J1 (Figure 2.1, Figure 2.3).
- 5.) Connect the RF OUT, J2, to the receiver under test (Figure 2.3).
- 6.) Set BCD switches SW1 to SW4 to the desired frequency (Figure 2.2).
- 7.) Be sure DS1 (green, DC Power) is on and DS2 (red, Alarm) is off (Figure 2.2).

2.5.2 Frequency Setting, SW1 to SW4 - The frequency is selected by setting the BCD switches (SW1 to SW4) on the front panel to the desired frequency using a small blade screwdriver. The frequency displayed on the BCD switches is the desired output frequency with 70 or 140 MHz IF center frequency input and the low or high side LO as selected by SW5 and SW6 (see Figure 2.2). There is no muting of the output carrier during frequency selection. If the switches are set to an invalid frequency, alarm LED DS2 will light.

2.5.3 LO and IF for the 2005-04

The 2005-04 operates over its full 950 to 2050 MHz range with high side LO and 70 MHz input. Normally, LNB's use high side LO for C-band and low side LO for Ku-band. Also, note that there will be a spectrum inversion of the input IF modulation with the high side LO. Although the 2005-04 operates over its full 950 to 2050 MHz range with high side LO and 70 MHz input only, it can be set for low side LO and 140 MHz operation over a limited range as Table 2.1 shows. The PLL will alarm if you try to operate the 2005-04 outside the allowable frequency range shown.

LO-Side	IF (MHz)	LO Range (MHz)	Allowable Frequency Range (MHz)
HIGH	70	1020-2120	950-2050
LOW	70	1020-1980	1090-2050
HIGH	140	1090-2120	950-1980
LOW	140	1020-1910	1160-2050

2.5.4 Selecting High Side LO, Low Side LO, 70MHz or 140 MHz Input - To select High Side LO, Low Side LO, 70MHz or 140 MHz Input set SW5 and SW6 on the front panel (see Figure 2.2) to the desired position.

2.5.5 Selecting the Gain - The gain of the 2005 can be selected for -5 dBm (HI gain) or -25 dBm (LOW gain), -10 dBm maximum IF input, with SW7 on the rear panel (see Figure 2.3).

3.0 Circuit Description

3.1 Block Diagram Description - 2005 (Figure 3.1) - The 70 or 140 MHz input (J1) signal first goes to slide switch S7 which allows selection of high (-5 dB) or low (-25 dB) gain. The signal next goes to the 75 to 50 ohm matching attenuator, R27, R36. The signal then goes to mixer A1 which receives the LO generated by VCO A2 and provides the LO \pm IF and LO unfiltered output. This signal next goes through 3.5 dB attenuator R34, R39, R40, amplifier U12 which provides approximately +19 dB gain, and then to the 50 to 75 ohm matching attenuator R25, R23.

Commands for the phase lock loop IC, U5, are provided serially from microprocessor U3 which receives frequency setting inputs from BCD switches S1 to S4.

Crystal oscillator A3 provides the 25 MHz reference frequency for the synthesizer U5. U8 and associated circuitry light alarm LED DS2 when phase lock is lost. U6 provides +30 VDC for the loop amplifier U4. Q1 and Q2 provide low noise regulated voltages for A2 and U5.

3.2 Controller Operation for 2005 Upconverter

3.2.1 General - The controller consists of a microprocessor and associated circuitry which receives inputs from

- a) the front panel frequency select switches (S1 to S4),
- b) the front panel IF Frequency slide switch (S5),
- c) the front panel high side LO / low side LO slide switch (S6)

The controller provides command signals to the

- a) phase lock loop IC (U5),

3.2.2 Frequency Setting, SW1 to SW4 - The frequency is selected by setting the BCD switches (SW1 to SW4) on the front panel to the desired frequency using a small blade screwdriver. The frequency displayed on the BCD switches is the desired output frequency with 70 or 140 MHz IF center frequency input and the low or high side LO as selected by front panel slide switches SW5 and SW6 (see Figure 2.2). There is no muting of the output carrier during frequency selection. If the switches are set to an invalid frequency, alarm LED DS2 will light.

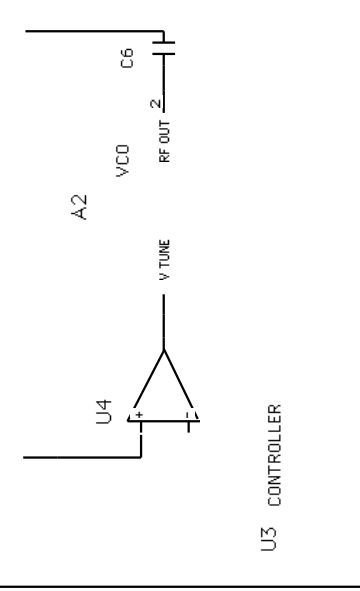
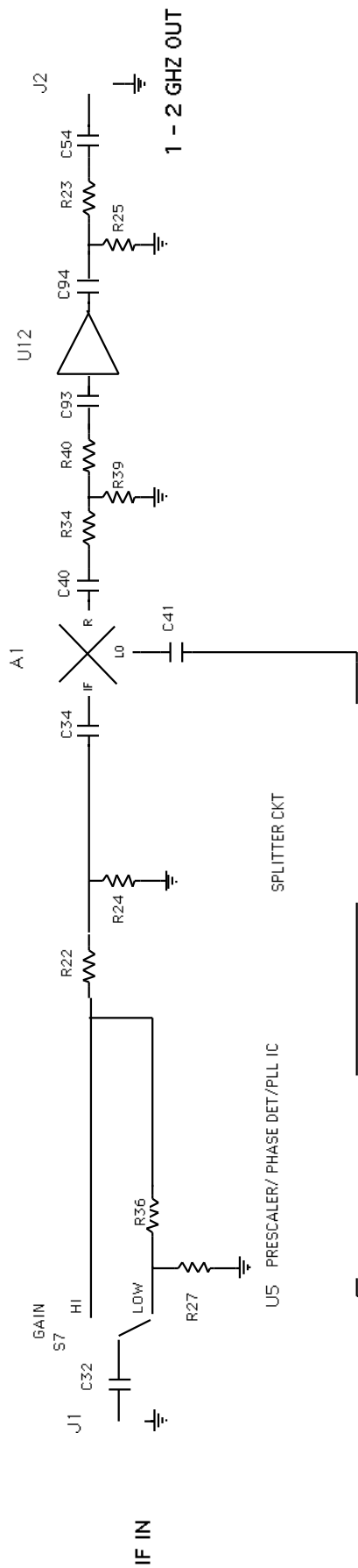

**FIGURE 3.1 2005-04,-05
TEST UPCONVERTER BLOCK
DIAGRAM**

4/14/03 HWW REV -

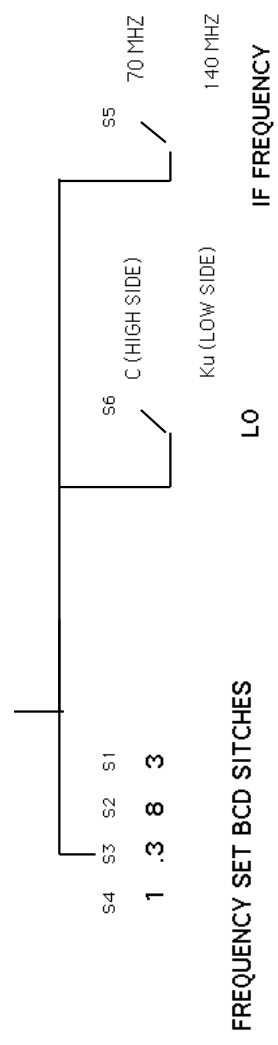

FRONT PANEL CONTROLS