

INSTRUCTION MANUAL

MODEL 2000-218 LNB Power Supply

Data, drawings, and other material contained herein are proprietary to Cross Technologies, Inc., but may be reproduced or duplicated without the prior permission of Cross Technologies, Inc. for purposes of operating the equipment.

When ordering parts from Cross Technologies, Inc., be sure to include the equipment model number, equipment serial number, and a description of the part.

First Edition, **August 2007** **Rev 0**

CROSS TECHNOLOGIES, INC.
6170 SHILOH ROAD
ALPHARETTA, GEORGIA 30005

(770) 886-8005
FAX (770) 886-7964
Toll Free 888-900-5588

WEB www.crosstechnologies.com
E-MAIL info@crosstechnologies.com

INSTRUCTION MANUAL

MODEL 2000-218 LNB Power Supply

<u>TABLE OF CONTENTS</u>	<u>PAGE</u>
Warranty	2
1.0 General	3
1.1 Equipment Description	3
1.2 Technical Characteristics	4
2.0 Installation	5
2.1 Mechanical	5
2.2 Rear Panel Inputs & Outputs	6
2.3 Front Panel Indicators	6
2.4 Operation	7

WARRANTY - The following warranty applies to all Cross Technologies, Inc. products.

All Cross Technologies, Inc. products are warranted against defective materials and workmanship for a period of one year after shipment to customer. Cross Technologies, Inc.'s obligation under this warranty is limited to repairing or, at Cross Technologies, Inc.'s option, replacing parts, subassemblies, or entire assemblies. Cross Technologies, Inc. shall not be liable for any special, indirect, or consequential damages. This warranty does not cover parts or equipment which have been subject to misuse, negligence, or accident by the customer during use. All shipping costs for warranty repairs will be prepaid by the customer. There are not other warranties, express or implied, except as stated herein.

**CROSS TECHNOLOGIES, INC.
6170 SHILOH ROAD
ALPHARETTA, GEORGIA 30005**

**(770) 886-8005
FAX (770) 886-7964
Toll Free 888-900-5588**

**WEB www.crosstechnologies.com
E-MAIL info@crosstechnologies.com**

MODEL 2000-218 LNB Power Supply

1.0 General

1.1 Equipment Description

The 2000-2XX LNB Power Supply is a switching power supply which provides regulated +18 VDC at 0.5 amps through RF connectors for insertion on an RF line. Also provided is a BNC connector for insertion of a 10 MHz reference signal on the RF line. The input AC connector is IEC 320 C13. The 2000-218 can be mounted on an optional 1 3/4" X 19 " rack mount panel (**option -R**).

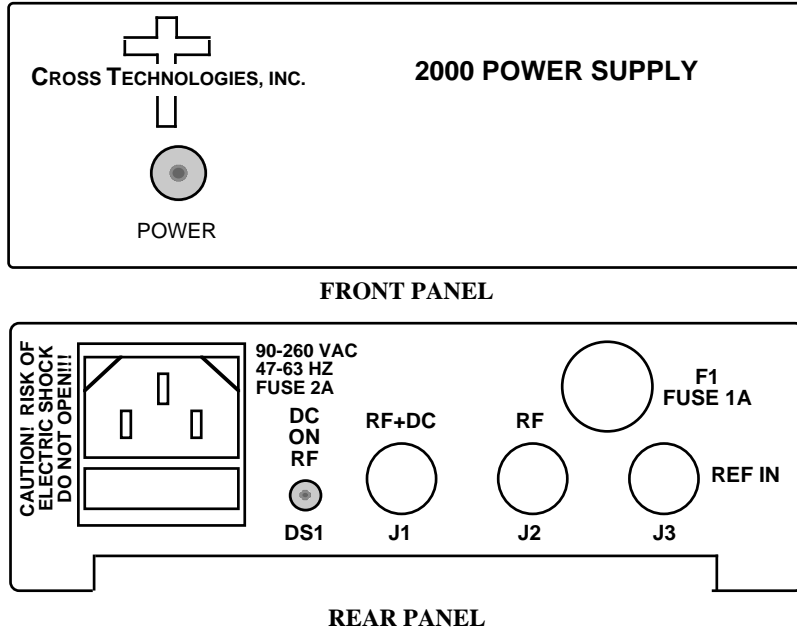

FIGURE 1.1 Front and Rear Panels

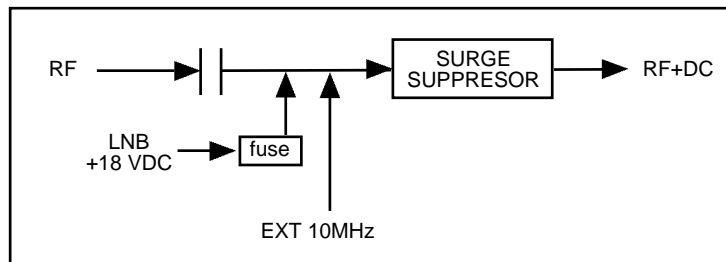

FIGURE 1.2 Block Diagram

1.2 Technical Characteristics

TABLE 1.0 2000-218 LNB Power Supply Specifications*

RF Input/Output Characteristics

Impedance/Return Loss	75 Ω /14 dB
Frequency	950 - 2150 MHz
Insertion Loss	1 \pm 0.5 dB
Frequency Response	\pm 1.0 dB

AC Input Characteristics

Voltage	90 - 260 VAC
Frequency	47 - 63 Hz
Power, maximum	20 watts

DC Output Characteristics

Voltage / Current	+18 VDC/ 0.5 amps
Load Regulation, max.	\pm 5%
Power Supply type	Switcher
Switching Frequency	50 kHz, typical

Indicators

DC Power (front)	Green LED
DC Power Insertion (rear)	Yellow LED

Other

AC Input Connector	IEC 320 C13
RF Connectors	Type F (female)
10MHz REF Connector	BNC (female), 50 Ω /75 Ω
Size, Bench Top	4.7" wide X 1.75" high X 8.5" deep
Size, Rack Mount	19 inch standard chassis 1.75"high X 9.0" deep (option R)

Options

R, R2, R3	Rack Mount Panel (1, 2, or 3 position)
Connectors/Impedance	see Table 2.2

*+10°C to +40°C; Specifications subject to change without notice

2.0 Installation

2.1 Mechanical

The 2000-218 is packaged in an aluminum extrusion. The **-R option** is mounted on a 1 3/4" X 19" panel that can be mounted to a rack using the 4 holes at the ends.

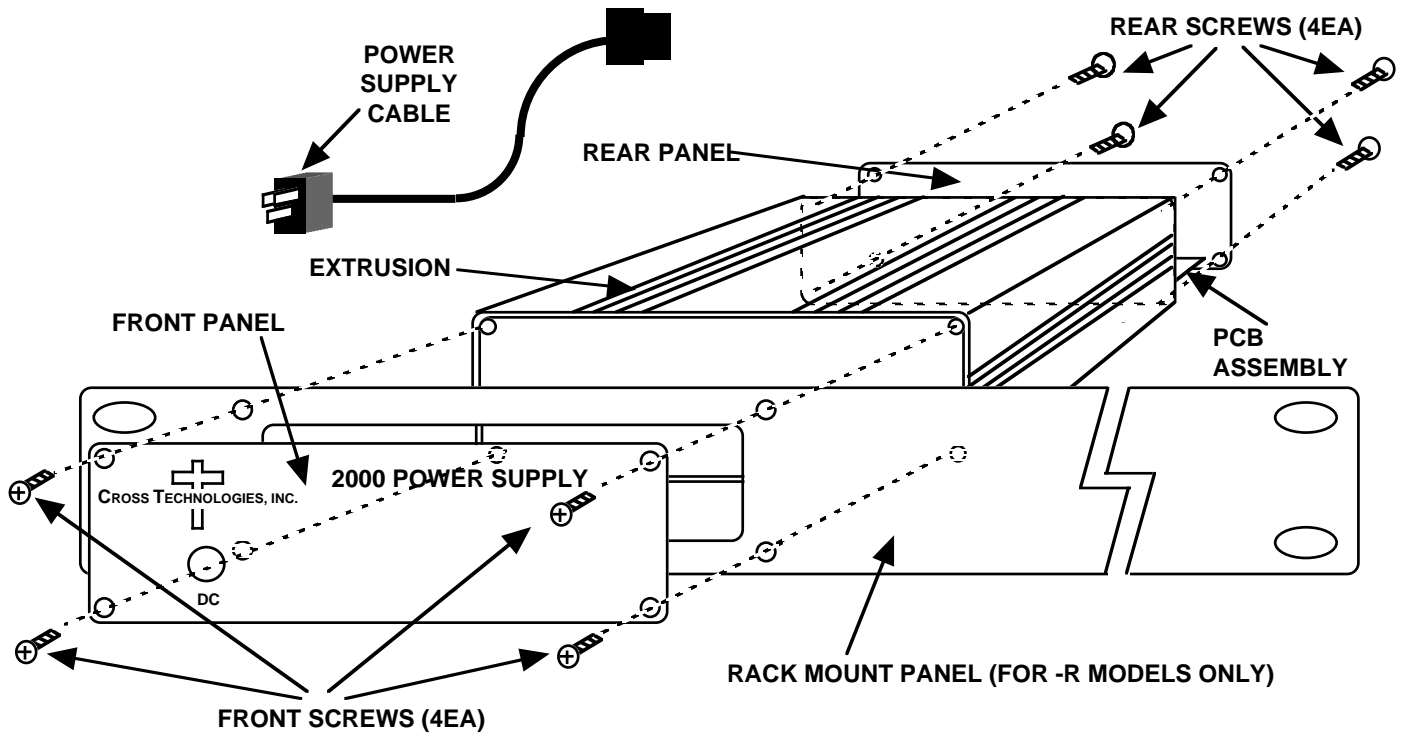

FIGURE 2.1 Mechanical Assembly (Rack Mounting)

2.2 Rear Panel Input/Output Signals - Figure 2.2 shows the input and output connectors on the rear panel.

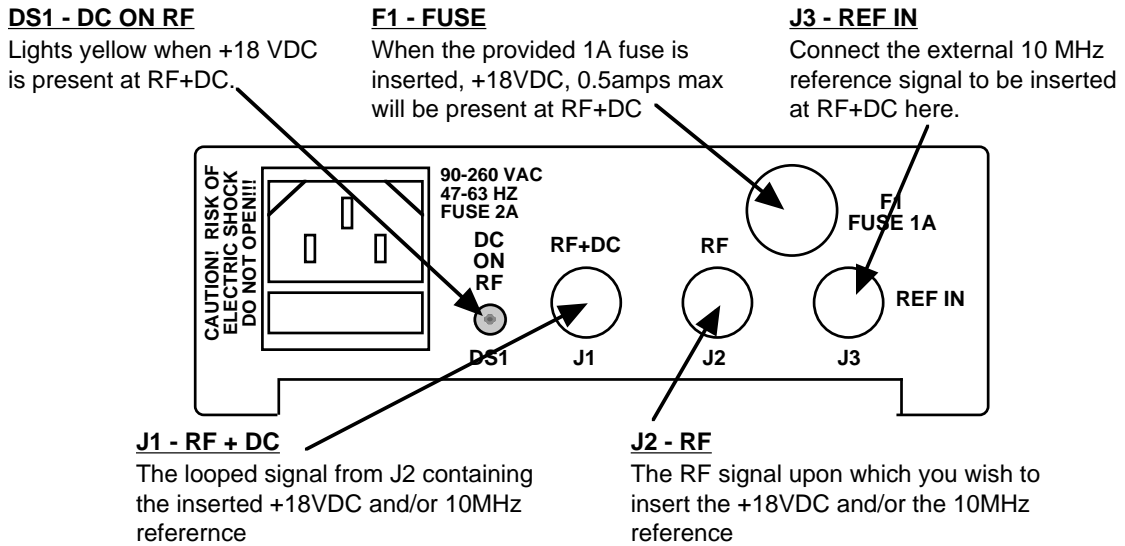

FIGURE 2.2 Rear Panel I/Os

TABLE 2.1 Connector Options	
Option	RF
STD	Type F, 75Ω
-B	BNC, 75Ω
-D	BNC, 50Ω

2.3 Front Panel Indicators - The following are the front panel indicators.

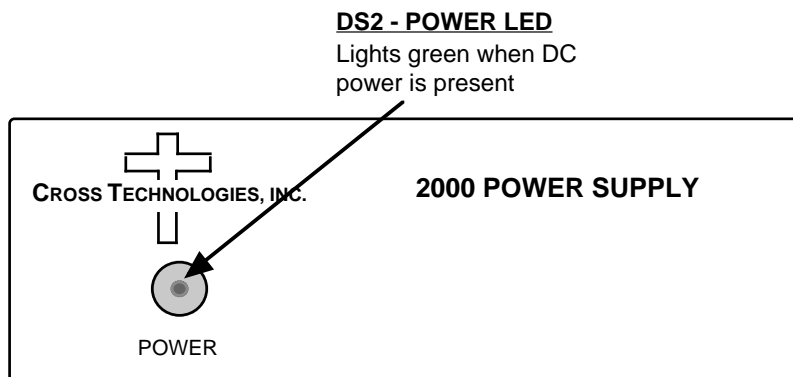

FIGURE 2.3 Front Panel Indicators

2.4 Operation

2.4.1 Installing and Operating the 2000-218 LNB Power Supply

1. Connect an RF signal to RF connector, J2 (Figure 2.2).
2. Connect RF+DC connector, J1, to the external equipment (Figure 2.2).
3. To insert +18VDC on the RF signal insert a 1 amp fuse (provided) in fuse holder, F1 (Figure 2.2).
4. To insert a 10MHz reference signal on the RF signal connect a 10MHz source to the REF IN, J3 (Figure 2.2).
5. Connect 90- 260 VAC, 47 - 63 Hz to AC on the back panel (Figure 2.2).
6. Be sure DS2 (green, DC Power) is on (Figure 2.3).
7. If fuse, F1, is inserted check that LNB Power LED, DS1, is on (Figure 2.2)
8. **AC FUSE** - The AC fuse is a 5 mm X 20 mm, 2 amp slow blow (Type T) and is inserted in the far slot in the drawer below the AC input as shown in Figure 2.4. There is a spare fuse in the near slot. If a fuse continues to open, the power supply is most likely defective.

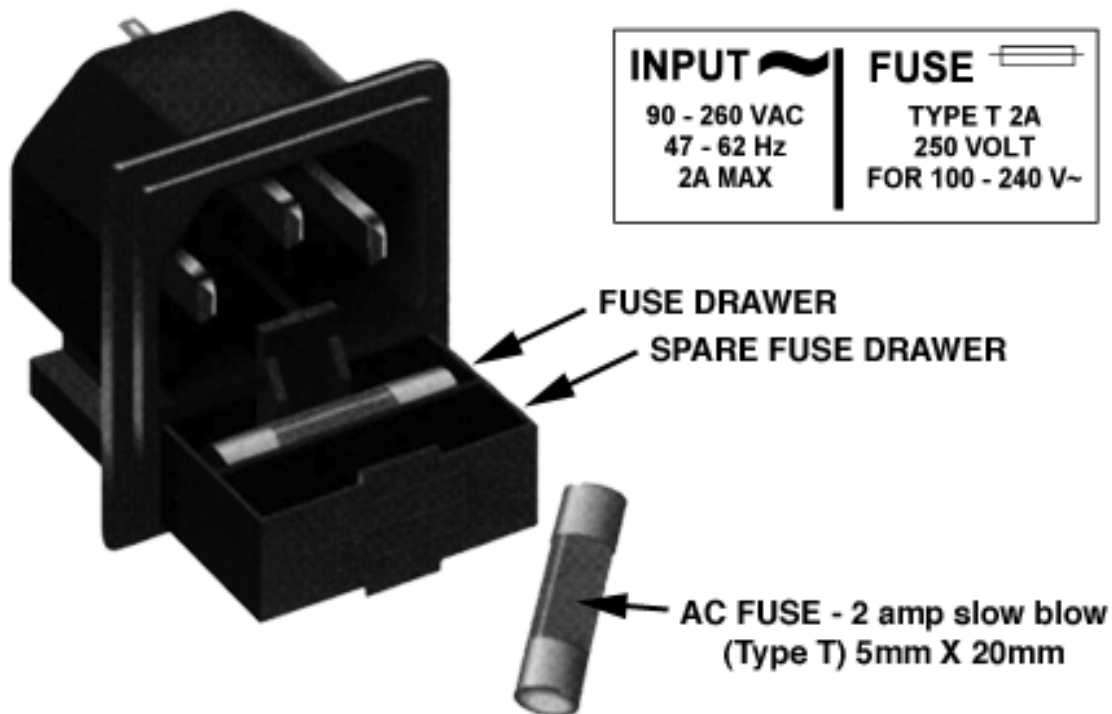

FIGURE 2.4 Fuse Location and Spare Fuse

**CROSS TECHNOLOGIES, INC.
6170 SHILOH ROAD
ALPHARETTA, GEORGIA 30005**

**(770) 886-8005
FAX (770) 886-7964
Toll Free 888-900-5588**

**WEB www.crosstechnologies.com
E-MAIL info@crosstechnologies.com**