

# Instruction Manual

# Model 162 Cue Trigger Switch

January 2009 Rev. C

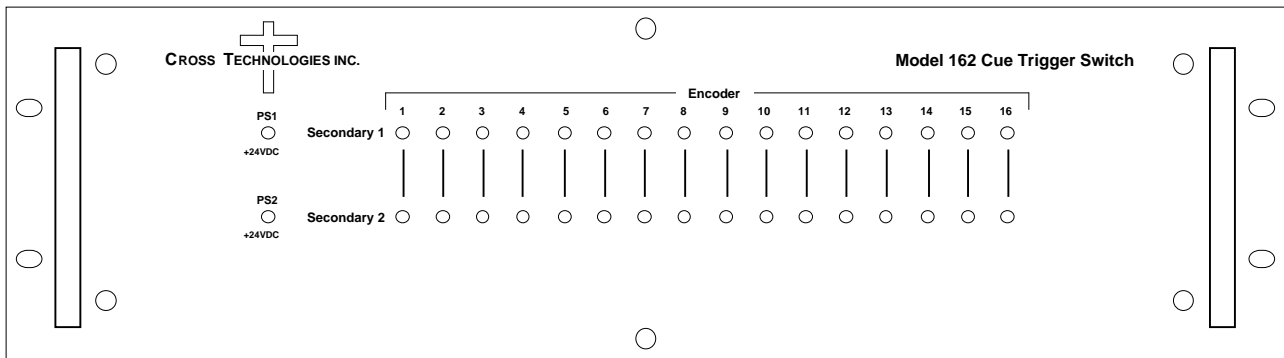

Data, drawings, and other material contained herein are proprietary to Cross Technologies, Inc., but may be reproduced or duplicated without the prior permission of Cross Technologies, Inc. for purposes of operating the equipment.

When ordering parts from Cross Technologies, Inc., be sure to include the equipment model number, equipment serial number, and a description of the part.



6170 Shiloh Road  
Alpharetta, Georgia 30005

(770) 886-8005  
FAX (770) 886-7964  
Toll Free 888-900-5588

WEB [www.crosstechnologies.com](http://www.crosstechnologies.com)  
E-MAIL [info@crosstechnologies.com](mailto:info@crosstechnologies.com)

# INSTRUCTION MANUAL

## MODEL 162 Cue Trigger Switch

<u>TABLE OF CONTENTS</u>	<u>PAGE</u>
Warranty	2
1.0 General	3
1.1 Equipment Description	3
1.2 Technical Characteristics	4
1.3 Use Information	5
2.0 Installation	6
2.1 Mechanical	6
2.2 Input / Output Signals	7
2.3 Indicators	9
2.4 Operation	9
2.5 Drawings	11

**WARRANTY** - The following warranty applies to all Cross Technologies, Inc. products.

All Cross Technologies, Inc. products are warranted against defective materials and workmanship for a period of one year after shipment to customer. Cross Technologies, Inc.'s obligation under this warranty is limited to repairing or, at Cross Technologies, Inc.'s option, replacing parts, subassemblies, or entire assemblies. Cross Technologies, Inc. shall not be liable for any special, indirect, or consequential damages. This warranty does not cover parts or equipment which have been subject to misuse, negligence, or accident by the customer during use. All shipping costs for warranty repairs will be prepaid by the customer. There are not other warranties, express or implied, except as stated herein.



6170 Shiloh Road  
Alpharetta, Georgia 30005

(770) 886-8005  
FAX (770) 886-7964  
Toll Free 888-900-5588

WEB [www.crosstechnologies.com](http://www.crosstechnologies.com)  
E-MAIL [info@crosstechnologies.com](mailto:info@crosstechnologies.com)

# MODEL 162 Cue Trigger Switch

## 1.0 General

**1.1 Equipment Description-** The Model 162 Cue Trigger Switch provides switching of 8 contact closures from each of 16 on-line encoders to two separate 8 line outputs that can go to two different secondary encoders. Switching is determined by providing a closure to ground to the corresponding channel relay control input pin. Or receipt of a switch contact closure input, two pairs of 4 Pole, double-throw high sensitivity relays switch 8 contact closures from one of 16 inputs to one of two secondary outputs. In the de-energized state, no signals are switched to the secondary outputs.

The 162 consists of two switch printed circuit boards (PCB), one interface PCB and one indicator front panel PCB housed in a 3 RU (5 1/4 inch high) by 20 inch deep chassis. Redundant, CE approved, covered, switching, +24 VDC power supplies with the DC output diode OR'd provide redundant power for the relays and LEDs.

Connectors are terminal strip (a two section terminal strip with removable screw terminal mating connector) for the contact closure inputs from the on-line encoders, DB9, female, for the signal passed through to the online encoder DB9, female, for the signals to the secondary encoders, and DB37, female, for the relay switch control closures.

Front panel green LEDs indicate which signals are being switched to the secondary encoders and presence of DC power from each power supply.

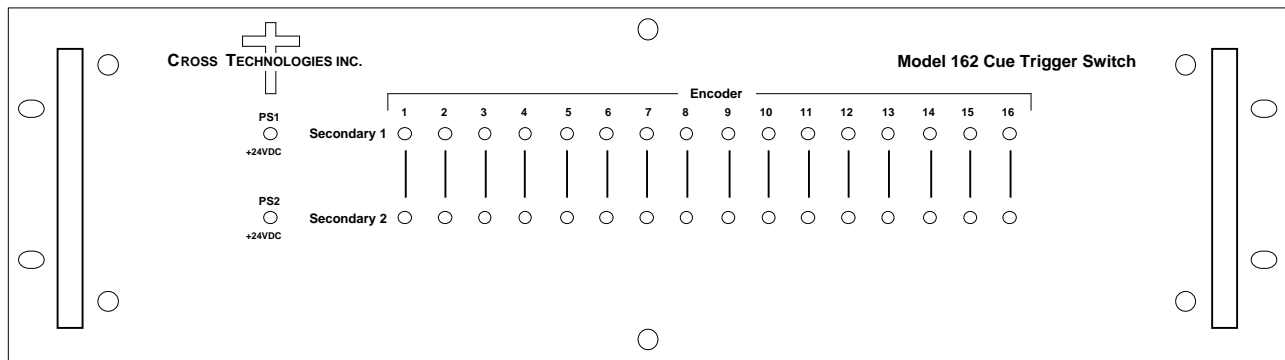

**FRONT PANEL**

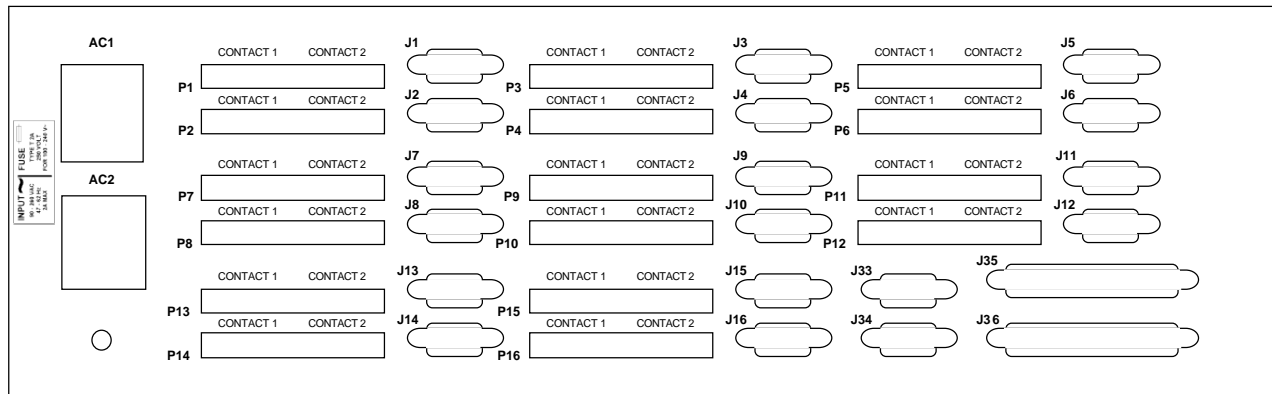

**REAR PANEL**

**Figure 1.1 Model 162 Front and Rear Panels**

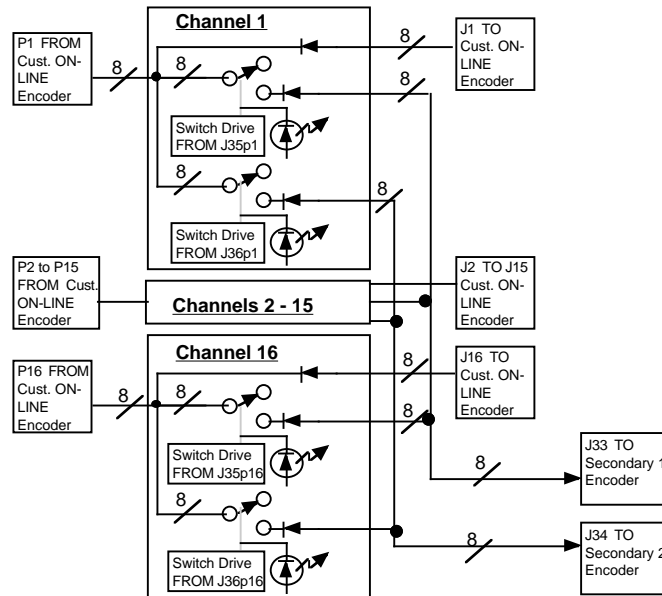

**Figure 1.2 Model 162 Cue Switch Block Diagram**

## 1.2 Technical Characteristics

**TABLE 1.0 162 Cue Trigger Switch SPECIFICATIONS**

<u>Characteristics</u>	<u>Specifications*</u>
<b>Inputs</b>	
From Online Encoders	16
Closures to ground per encoder	8
Polarity	If there is a voltage in the non-switched to ground state, it must be a positive voltage that is > or = to the voltage on the pass through output
<b>Outputs</b>	
To Online Encoders (pass thru)	16
To Secondary Encoders	2
Closures to ground per encoder	8
Polarity	Must be a positive voltage that is being switched to ground
<b>Relay Specifications (Encoder closure switch)</b>	
Contact current	500ma, max
Contact Voltage	50 volts DC, max
<b>Control signal Specification (closure to ground to switch relays)</b>	
Control current	30 ma, max
Voltage when open	25 volts DC, max
<b>Indicators</b>	
Power, Selection	Green LED indicate Power supply on, Channels selected for secondary 1, 2
<b>Other</b>	
AC Power, Input	100-240 ±10% VAC, 47 - 63 Hz, 30 watts, max
AC Fuse	2 amp slow blow (Type T), 5 mm X 20 mm
Size	19" W X 5 1/4" H X 21" D

\*+10 to +40 degrees C; 2000 meters max elevation; 80% max humidity; Pollution Degree 2; Specifications subject to change without notice.

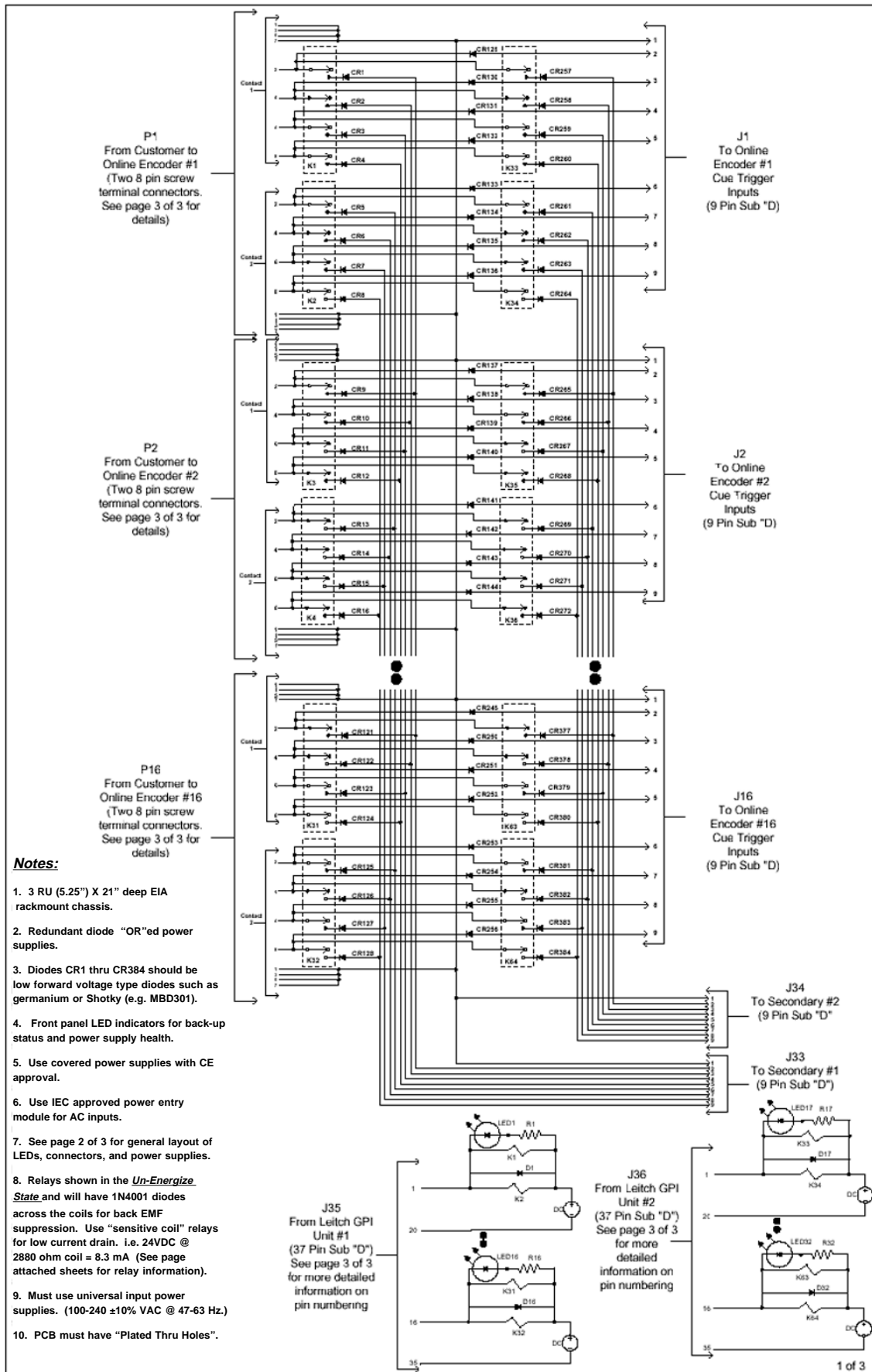

**FIGURE 1.3 DETAILED BLOCK DIAGRAM**

### 1.3 Use Information

- A. **Elevated operating ambient temperature** - if installed in a closed or multi-unit rack assembly, the operating ambient temperature of the rack may be greater than room ambient temperature. Therefore, consideration should be given to Tmra.
- B. **Reduced air flow** - Installation of the equipment in a rack should be such that the amount of air flow required for safe operation of the equipment is not compromised. Additional space between unit may be required.
- C. **Mechanical loading** - Mounting of equipment in a rack should be such that a hazardous condition does not exist due to uneven weight distribution.
- D. **Circuit Overloading** - Consideration should be given to the connection of the equipment to the supply circuit and the effect that overloading of circuits could have on over current protection and supply wiring. Appropriate consideration of equipment name plate rating should be used, when addressing this concern.
- E. **Reliable Earthing** - Reliable earthing of rack-mounted equipment should be maintained. Particular attention should be given to supply connections other than direct connection to the Branch (use of power strips).
- F. **Top Cover** - There are no servicable parts inside the product so, the Top Cover should not be removed. If the Top Cover is removed the ground strap and associated screw **MUST BE RE-INSTALLED** prior to Top Cover screw replacement. **FAILURE TO DO** this may cause **INGRESS** and/or **EGRESS** emission problems.

### 2.0 Installation

- 2.1 **Mechanical** - The 162 consists of two switch printed circuit boards (PCB), one interface PCB and one indicator front panel PCB housed in a 3 RU (5 1/4 inch high) by 20 inch deep chassis. Redundant, CE approved, covered, switching, +24 VDC power supplies with the DC output diode OR'd provide redundant power for the relays and LEDs. Connectors are terminal strip (a two section terminal strip with removable screw terminal mating connector) for the contact closure inputs from the on-line encoders, DB9, female, for the signal passed through to the online encoders, DB9, female, for the signals to the secondary encoders, and DB37, female, for the relay switch control closures. The 162 can be secured to a rack using the 4 holes on the front panel. Figure 2.1 shows how the 162 is assembled.

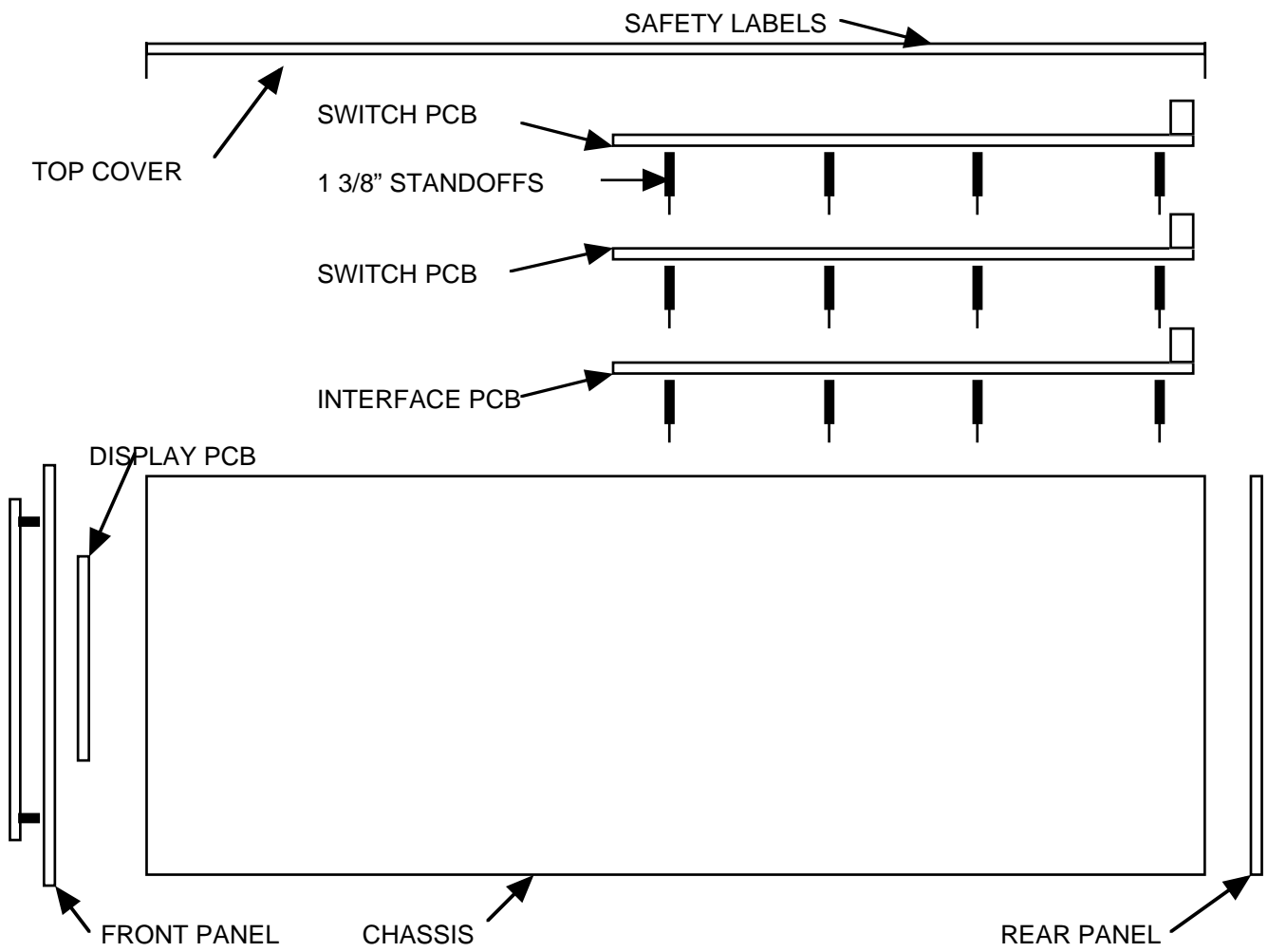

**FIGURE 2.0 162 MECHANICAL ASSEMBLY**

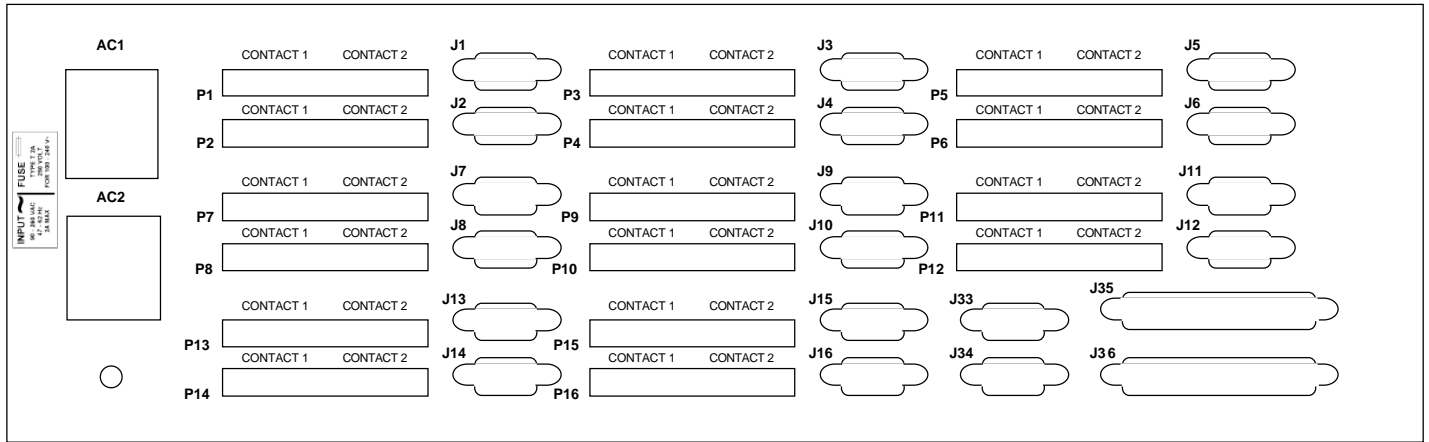

**FIGURE 2.1 162 REAR PANEL**

**2.2 Input/Output Signals** - The input and output connectors on the rear panel consist of the following:

- A) **P1 - P16** Terminal Strip for the contact closure inputs from the on-line encoders number 1 (P1) through number 16 (P16). This is a two section terminal strip with removable screw terminal mating connector. Figure 2.2 shows the pin configuration.
- B) **J1 - J16** DB9, female, for the signal passed through to online encoders number 1 (J1) to number 16 (J16). Figure 2.3 shows the pin configuration.
- C) **J33, J34** DB9, female, for the signal passed to the secondary encoders number 1 (J33) or number 2 (J34). Figure 2.3 shows the pin configuration. Any input (P1 to P16) can be switched to either or both J33 and J34.
- D) **J35, J36** DB37, female, for the contact closure control that selects which online encoder lines are switched to the secondary encoders. Control for number 1 is on J35 and control for number 2 is J36. Figure 2.4 shows the pin configuration.

**CAUTION!** ONLY ONE CONTROL PIN OF J35 AND ONE CONTROL PIN OF J36 CAN BE GROUNDED AT ONE TIME.

E) **AC1, AC2 - POWER IN** - Provides AC inputs for dual power supplies.

Figures 2.2, 2.3, 2.4 show the pinouts for the input and output connectors.

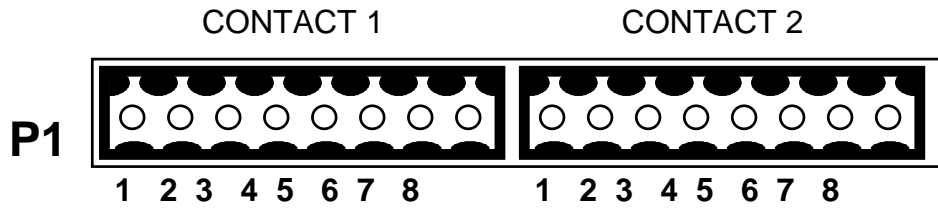

TERMINAL STRIP PIN DESCRIPTIONS (P1 - P16)		
PIN	CONTACT 1	CONTACT 2
1, 3, 5, 7	GROUND	GROUND
2	LINE 1 IN	LINE 5 IN
4	LINE 2 IN	LINE 6 IN
6	LINE 3 IN	LINE 7 IN
8	LINE 4 IN	LINE 8 IN

**FIGURE 2.2 TERMINAL STRIP PIN OUTS P1 - P16**

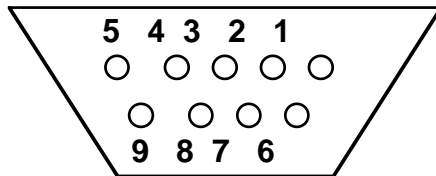

DB9 PIN DESCRIPTIONS (J1 - J16, J33-34)	
PIN NUMBER	DESCRIPTION
1	GROUND
2	LINE 1 OUT
3	LINE 2 OUT
4	LINE 3 OUT
5	LINE 4 OUT
6	LINE 5 OUT
7	LINE 6 OUT
8	LINE 7 OUT
9	LINE 8 OUT

**FIGURE 2.3 DB9 PIN OUTS J1 - J16. J33 - 34**

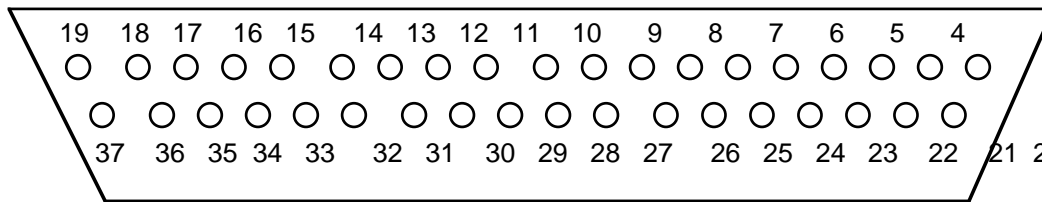

- A) PIN 1= CONTROL 1, PIN2= CONTROL 2,....PIN 16= CONTROL 16
- B) PINS 20 TO 35, PIN 37 = GROUND
- C) PINS 17, 18, 19, 36 = NO CONNECTION

**FIGURE 2.4 DB37 PIN OUTS J35, J36**

**2.3 Indicators -** The following are the indicators.

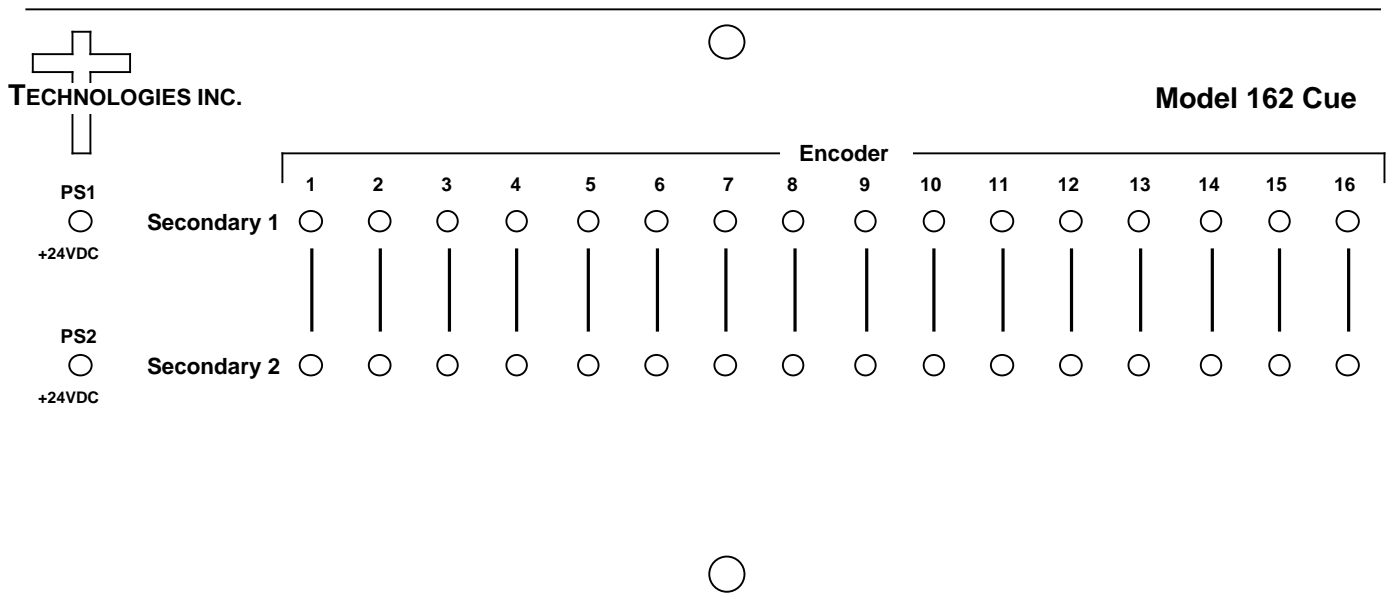

**FIGURE 2.5 162 INDICATORS**

**TABLE 2.1 FRONT PANEL INDICATORS**

<u>Item</u>	<u>Description</u>
SECONDARY 1 LEDs	Green LED indicates which Input Channel goes to the Secondary 1 output
SECONDARY 2 LEDs	Green LED indicates which Input Channel goes to the Secondary 2 output
PS1 LED	Turns green when power is applied to AC1 input on the rear panel
PS2 LED	Turns green when power is applied to AC2 input on the rear panel

## 2.4 Operation

- 1.) **CAUTION!** OBSERVE AND HEED SAFETY LABELS ON TOP COVER (see FIGURE 2.6).
- 2.) Connect interface cables to the 162 (See Section 2.2 for connector descriptions and pinouts).
- 3.) Connect 100-240  $\pm$ 10% VAC, 47 - 63 Hz to AC1 and AC2 on the back panel and observe PS1 and PS2 LEDs are lit.
- 4.) Apply one contact closure to the desired control pin of J35 and J36 and observe the proper switching of signals. Observe the corresponding LEDs on the front panels are lit.
- 5.) **AC Fuse** - The fuse is a 5 mm X 20 mm, 2 amp slow blow (Type T) and is inserted in the far slot in the drawer below the AC input as shown in Figure 2.7. There is a spare fuse in the near slot. If a fuse continues to open, the power supply is most likely defective.

This Class A digital apparatus meets all requirements of the Canadian interference causing equipment regulations.

Cet appareil numérique de la classe A est respecte toutes les exigences du reglement sur le material broilleur du Canada.

### CAUTION

TO REDUCE THE RISK OF ELECTRICAL SHOCK, DO NOT REMOVE COVERS FROM THIS UNIT NO USER SERVICEABLE PARTS INSIDE. REFER SERVICING TO QUALIFIED PERSONNELL. SEE ADDITIONAL SAFETY INSTRUCTIONS IN MANUAL.

Cross Technologies, Inc.  
Made in U.S.A.

**CAUTION:** FOR CONTINUED PROTECTION AGAINST FIRE REPLACE ONLY WITH SAME TYPE FUSE T 2A 250 VOLT FOR 100 - 240 V~



**CAUTION:** THIS EQUIPMENT MAY HAVE UP TO TWO POWER SUPPLY CORDS. TO REDUCE THE RISK OF ELECTRIC SHOCK, TWO POWER SUPPLY CORDS MAY HAVE TO BE DISCONNECTED BEFORE SERVICING.

**FIGURE 2.6 SAFETY DECALS ON TOP COVER**

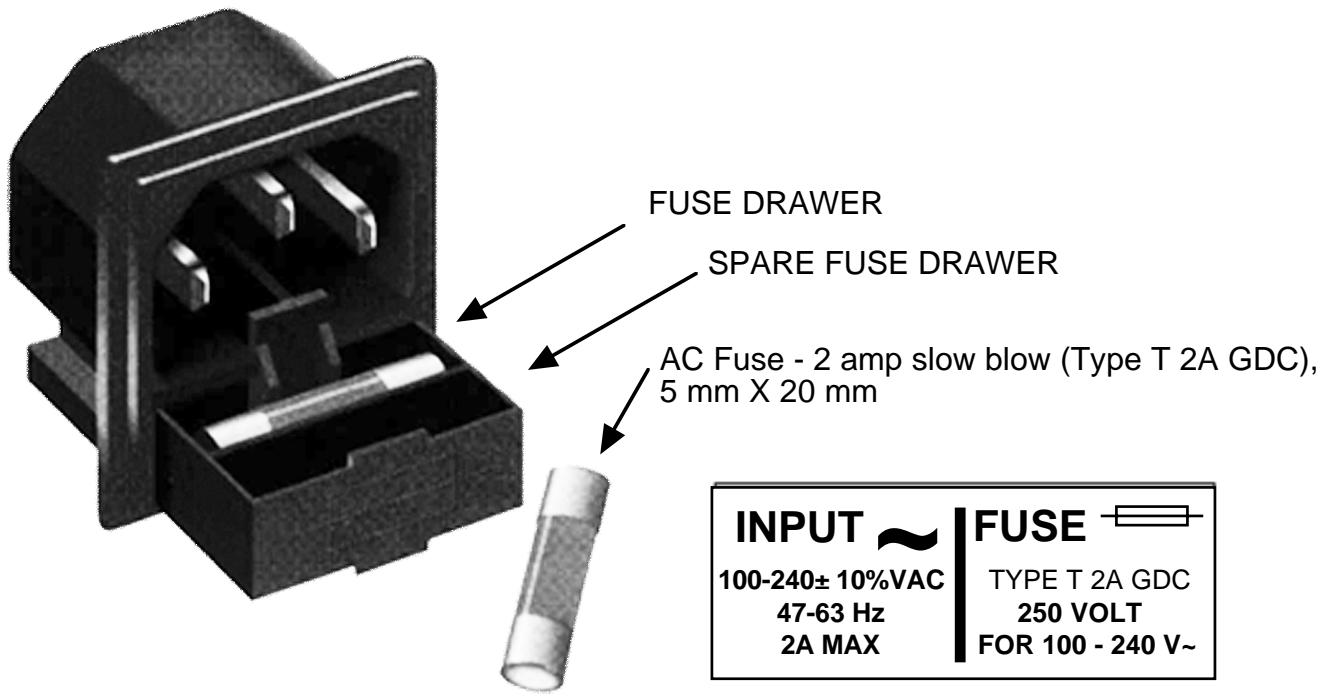

**FIGURE 2.7 FUSE LOCATION AND SPARE FUSE**

TABLE 2.2 SWITCH CONTROL		TABLE	
GROUND ON J35, pin	SIGNAL THAT IS SWITCHED TO J33	GROUND ON J36, pin	SIGNAL THAT IS SWITCHED TO J34
1	P1	1	P1
2	P2	2	P2
3	P3	3	P3
4	P4	4	P4
5	P5	5	P5
6	P6	6	P6
7	P7	7	P7
8	P8	8	P8
9	P9	9	P9
10	P10	10	P10
11	P11	11	P11
12	P12	12	P12
13	P13	13	P13
14	P14	14	P14
15	P15	15	P15
16	P16	16	P16

**2.5 Drawings** - Table 2.3 shows the list of drawings for the 162.

<b>TABLE 2.3 MODEL 162 Cue Switch DRAWINGS</b>		
<b>DRAWING NO.</b>	<b>DESCRIPTION</b>	<b>PAGES</b>
70225	Schematic, Interconnect, Cue Switch	1
70226	Panel, Front, 162 Cue Switch	1
70227	Panel, Rear, 162 Cue Switch	1
70228	Chassis, bottom, 20"	1
70229	Chassis, cover, 20"	1
70230	Schematic, Display (front panel)	1
70231	PWB Display (front panel)	1
70232	PWB Assy, Display (front panel)	1
70233	Schematic, Switch (top/middle)	2
70234	PWB, Switch (top/middle)	1
70235	PWB Assy, Switch (top/middle)	1
70236	Schematic, Switch, Interface (bottom)	2
70237	PWB, Switch, Interface (bottom)	1
70238	PWB Assy, Switch, Interface (bottom)	1
70240	Plate, Power Supply	1



**CROSS TECHNOLOGIES, INC.**

6170 Shiloh Road  
Alpharetta, Georgia 30005

(770) 886-8005  
FAX (770) 886-7964  
Toll Free 888-900-5588

WEB [www.crosstechnologies.com](http://www.crosstechnologies.com)  
E-MAIL [info@crosstechnologies.com](mailto:info@crosstechnologies.com)