

4117-14 Block Up, Downconverter Weather Resistant*

The 4117-14 Block Up, Downconverter converts a 0.2 - 0.4 GHz block to 1.2 - 1.4 GHz and a 1.2 - 1.4 GHz block to 0.2 - 0.4 GHz. Front panel LEDs provide indication of DC Power, and PLL Alarms. The maximum gain is +30 dB for the Up and Downconverter. Connectors are Type N female for the UHF, L-band and L-band Monitor and SMA female for the external reference input. Gain, and internal 10 MHz frequency are controlled by the Ethernet M&C. In **AUTO**, the 10 MHz reference stays in external if the external level is in the +2 to +8 dBm range. The 4117-14 is powered by a 100-240 ± 10% power supply, and is mounted in a 8" W X 6" H X 16" D Weather Resistant* Enclosure.

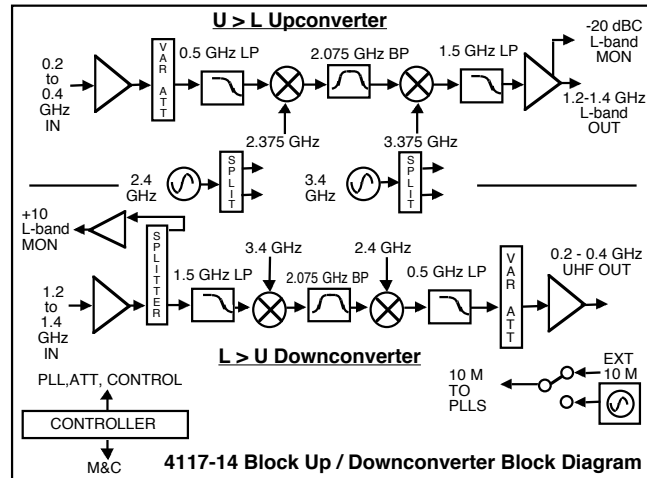
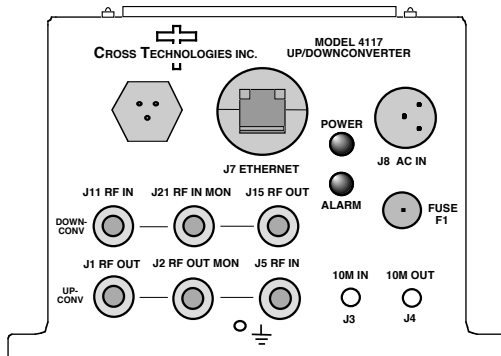

EQUIPMENT SPECIFICATIONS*		
Input Characteristics	UP, UHF, L	DOWN, L, UHF
Impedance/Return Loss	50Ω/14 dB	50Ω/14 dB
Frequency	0.2 to 0.4 GHz	1.2 - 1.4 GHz
Noise Figure, Max.	20 dB max gain	15 dB max gain
Input Level range	-40 to -25 dBm	-50 to -30 dBm
Output Characteristics		
Impedance/Return Loss	50 Ω /14 dB	50 Ω /14 dB
Frequency (GHz)	1.2 - 1.4 GHz	0.2 - 0.4
Output Level Range	-15 to 0 dBm	-20 to 0 dBm
1 dB comp, max gain	+10 dBm	+10 dBm
Monitor Level	-20 dBC OUT	+10 dB IN
Mute @ 0 dBm out	>60 dB	N/A
Channel Characteristics		
Gain, max. at Fc	+30 ±3 dB	+30 ±3 dB
Gain, range, 0.5dB steps	+30 to 0 dB	+30 to 0 dB
Image Rejection	> 55 dB, min	> 50 dB, min
Spurious, Inband, sig. rel.	<-55 dBC, 0dBm	<-50 dBC, 0dBm
Spurious, Inband, sig. ind.	<-60 dBm	<-60 dBm
Spurious, Out of band	<-55dBm 1 - 1.6 GHz out	<-45dBm 0.1-0.6 GHz out
Intermod - 2 carriers 4MHz space @ -10dBm	<-50 dBC	<-50 dBC
Frequency Resp. band	±2 dB	±2 dB
Frequency Resp. 40 MHz	± 0.5 dB	± 0.5 dB
Frequency Sense	Non-inverting	Non-inverting
Downconverter 2nd Harm		
≥ -40 dBC @ max. input level		.2-.4 GHz out

*Weather Resistant enclosures are designed to be water resistant for installation in an outdoor enclosure/antenna hut OR mounted outdoors on an antenna assembly at their specified temperature ranges. They are designed to be located "out in the elements" (water, sleet, snow, etc.) but they are *not* designed to be "submerged under" water.

If an extended temperature range is required, there is an **Extended Temperature** option (**Option W21**; -30°C to +60°C) available at an additional cost. Contact Cross for quote.

LO Characteristics

LO Frequency See Block Diagram, Translation is fixed
 Frequency Accuracy ± 0.05 ppm max over temp internal reference; ext. ref. input
 10 MHz level In Input =+2 to +8 dBm in, 50 ohms

Phase Noise @ F (Hz) >	100	1K	10K	100K	1M
dBC/Hz	-70	-80	-85	-100	-110

Controls, Indicators

Gain, Band, 10M Freq. Gain and internal 10 MHz frequency via Ethernet M&C or Status/Control Connector.
 Power; PLL Alarm Green LED: Red LED, External contact closure

Other

L-band/UHF/Monitor Port Connectors Type N (female), 50Ω
 10 MHz Connector SMA (female), 50Ω
 Ethernet Connector Standard RJ45 Weather Resistant* Ethernet Connector
 Size 8" wide X 6" high X 16" deep Weather Resistant* Enclosure
 Power 100-240 ±10% VAC, 47 - 63 Hz, 25 watts max./ FCI Clipper Series CL1M1102 Connector

**+0 to +50 degrees C; Specifications subject to change without notice