

2115-34 Block Upconverter, 3.4-4.2 GHz, Non-Inverting

The 2115-34 Block Upconverter converts 0.95 - 1.75 GHz to 3.4 - 4.2 GHz with low phase noise and flat frequency response. Dual conversion frequency translation is via 11.26 and 8.81 GHz local oscillators. Front panel LEDs provide indication of DC Power, External 10 MHz, and PLL Alarm. The gain is +20 dB. Connectors are Type N female for the RF and BNC female for the L-Band and external reference input and reference output. A three-way switch controls which 10 MHz reference is being used. In the INT position, the internal reference is used, in the EXT position, the external reference is used, and in the AUTO position, the internal reference is used unless a 3 dBm \pm 3 dB, 10MHz reference signal is connected to the external reference input. The 2115 is powered by a 100-240 \pm 10% VAC power supply, and mounted in a 1 3/4" X 19" X 14" rack mount chassis.



2115-34 Upconverter

EQUIPMENT SPECIFICATIONS*

Input Characteristics

Impedance/Return Loss	50 Ω /14 dB
Frequency	0.95 to 1.75 GHz
Noise Figure, Max.	20 dB max gain
Input Level range	-40 to -20 dBm
Input 1 dB compression	-10 dBm

Output Characteristics

Impedance/Return Loss	50 Ω /14 dB
Frequency	3.4 to 4.2 GHz
Output Level Range	-20 to 0 dBm
Output 1 dB compression	+5 dBm

Channel Characteristics

Gain	+20 dB \pm 1 dB
Image Rejection	> 60 dB, min
Spurious, Inband	SIGNAL RELATED <-55 dBC in band, 0 dBm out; SIGNAL INDEPENDENT, <-60 dBm
Spurious, Out of band	<-50 dBm
Intermodulation	<-50 dBC for two carriers each at -10 dBm out
Frequency Response	\pm 1.5 dB, 3.4 - 4.2 GHz out; \pm 0.5 dB, 40 MHz BW
Frequency Sense	Non-inverting

LO Characteristics

LO Frequency	11.26 and 8.81 GHz
Frequency Accuracy	\pm 0.01 ppm max over temp internal reference; external reference input
10 MHz level (In/Out)	3 dBm, \pm 3 dB

Phase Noise @ F (Hz) >	100	1K	10K	100K	1M
dBC/Hz	-70	-80	-85	-100	-110

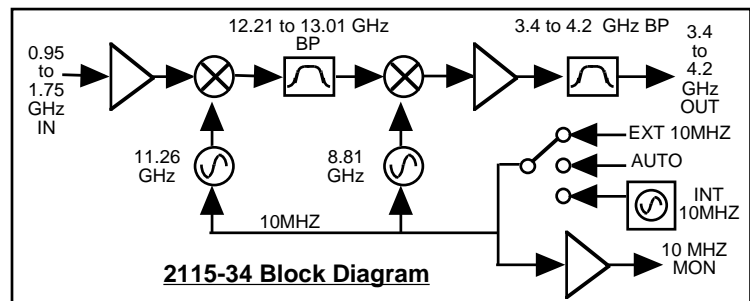

Controls, Indicators

Power	Green LED
PLL Alarm	Red LED, External contact closure
Ext 10 MHz	Yellow LED, indicates external 10 MHz reference selected (rear panel DPDT switch)

Other

RF Connector	Type-N (female), 50 Ω
L-Band Connector	BNC (female), 50 Ω
10 MHz Connectors	BNC (female), 50/75 Ω
Alarm Connector	DB9 - NO or NC contact closure on Alarm
Size	19 inch standard chassis 1.75" high X 14.0" deep
Power	100-240 \pm 10% VAC, 47 - 63 Hz, 25 watts max.

Available Connector Options

N - 50 Ω N-type (RF), 75 Ω BNC (L-BAND)
 NF - 50 Ω N-type (RF), 75 Ω F-type (L-BAND)
 NN - 50 Ω N-type (RF), 50 Ω N-type (L-BAND)
S - 50 Ω SMA (RF), 50 Ω BNC (L-BAND)
 S7 - 50 Ω SMA (RF), 75 Ω BNC (L-BAND)
 SF- 50 Ω SMA (RF), 75 Ω F-type (L-BAND)
 SN - 50 Ω SMA (RF), 50 Ω N-type (L-BAND)
 SS - 50 Ω SMA (RF), 50 Ω SMA (L-BAND)

Options

Connectors	Contact Cross Sales for option numbers
------------	--

*+10°C to +40°C; Specifications subject to change without notice.