

**2115-114 Block Upconverter, 11.45 - 12.25 GHz**

The 2115-114 Block Upconverter converts 0.95 - 1.75 GHz to 11.45 - 12.25 GHz with a local oscillator at 10.5 GHz. Front panel LEDs provide indication of DC Power, External 10 MHz, and PLL Alarm. The L-band to RF gain is +20 dB. Connectors are SMA female for the RF and BNC female for the L-Band and external reference input and reference output. A three-way switch controls which 10 MHz reference is being used. In the INT position, the internal reference is used, in the EXT position, the external reference is used, and in the AUTO position, the internal reference is used unless a +3 dBm ± 3 dB, 10MHz reference signal is connected to the external reference input. The 2115 is powered by a 100-240 ± 10% VAC power supply, and mounted in a 1 3/4" X 19" X 14" rack mount chassis.

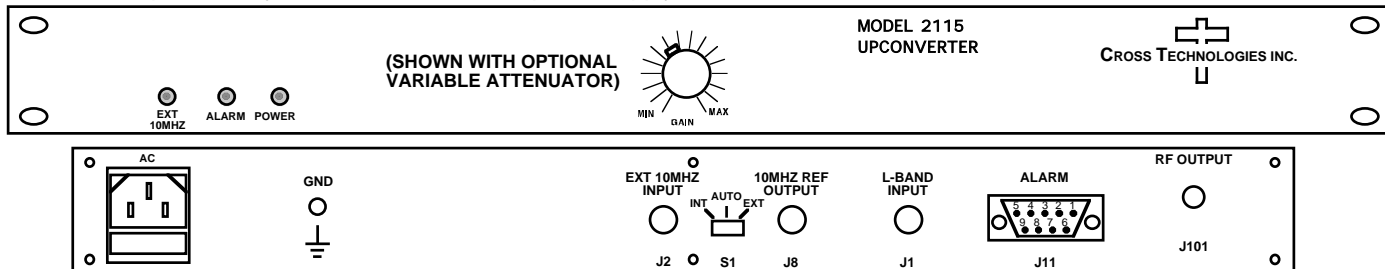

**Front and Rear Panels**

**EQUIPMENT SPECIFICATIONS\***

**Input Characteristics**

Impedance/Return Loss 50Ω/14 dB  
 Frequency 0.95 to 1.75 GHz  
 Noise Figure, Max. 20 dB max gain  
 Input Level range -40 to -25 dBm  
 Input 1 dB compression -15 dBm

**Output Characteristics**

Impedance/Return Loss 50 Ω /14 dB  
 Frequency 11.45 to 12.25 GHz

Output Level Range -20 to -5 dBm  
 Output 1 dB compression +5 dBm

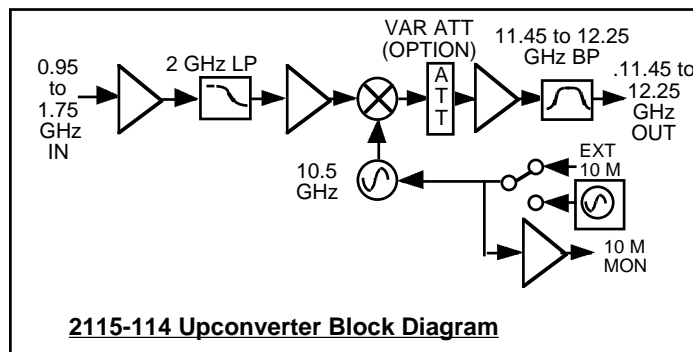

**2115-114 Upconverter Block Diagram**

**Channel Characteristics**

Gain +20 ±1 dB, (+20 to +5 dB continuously variable with Variable Attenuator Option)  
 Image Rejection > 60 dB, min  
 Spurious, Inband SIGNAL RELATED <-60 dBC in band, -5 dBm out; SIGNAL INDEPENDENT, <-60 dBm  
 Spurious, Out of band <-50 dBm  
 Intermodulation <-50 dBC for two carriers each at -10 dBm out  
 Frequency Response ±1 dB, 11.45 - 12.25 GHz out; ± 0.5 dB, 40 MHz BW  
 Frequency Sense Non-inverting

**LO Characteristics**

LO Frequency 10.5 GHz  
 Frequency Accuracy ± 0.01 ppm max over temp internal reference; ext. ref. input

Phase Noise @ F (Hz) >	100	1K	10K	100K	1M
dBC/Hz	-70	-80	-85	-100	-110

10 MHz level +3 dBm, ± 3 dB, 75 ohms, External In or Internal out

**Controls, Indicators**

Attenuator Option -VA Provides +20 to +5 dB continuously variable gain via front panel variable potentiometer.  
 Ext 10 MHz Yellow LED, indicates external 10 MHz reference selected (rear panel DPDT switch)  
 PLL Alarm Red LED, External contact closure  
 Power Green LED

**Other**

RF Connector SMA (female), 50Ω  
 L-Band Connector BNC (female), 50Ω  
 10 MHz connectors BNC (female), 75Ω connector; Works for 50Ω or 75Ω  
 Alarm Connector DB9 - NO or NC contact closure on Alarm  
 Size 19 inch standard chassis 1.75" high X 14.0" deep  
 Power 100-240 ±10% VAC, 47 - 63 Hz, 25 watts max.

**Available Connector Options**

M - 50Ω N-type (RF), 50Ω BNC (L-BAND)  
 N - 50Ω N-type (RF), 75Ω BNC (L-BAND)  
 NF - 50Ω N-type (RF), 75Ω F-type (L-BAND)  
 NN - 50Ω N-type (RF), 50Ω N-type (L-BAND)  
 S7 - 50Ω SMA (RF), 75Ω BNC (L-BAND)  
 SF - 50Ω SMA (RF), 75Ω F-type (L-BAND)  
 SN - 50Ω SMA (RF), 50Ω N-type (L-BAND)  
 SS - 50Ω SMA (RF), 50Ω SMA (L-BAND)

\*+10 to +40 degrees C; Specifications subject to change without notice