

2083-5018# Block Translator, 2000-5500 MHz to 950-1750 MHz

2083-5018# Block Translator - The 2083-5018# Block Translator converts a **800 MHz** block in the 2000-5500 MHz input to the 950-1750 MHz block with no spectrum inversion, low group delay and flat frequency response. The 2000-5500 MHz input is filtered and translated to the 950-1750 MHz block output using dual conversion. The **gain can be set for 0 to +30 dB, in 1 ±1dB steps. Multifunction switches select the Gain and the input band** which appear on the LCD display and can be adjusted remotely. Front panel LEDs provide indication of DC power (green), PLL alarm (red), and remote operation (yellow). Connectors are **SMA female** for RF input and **N female for the RF output** and BNC female for the external 10 MHz reference input and 10 MHz reference output. The 10 MHz output connector contains either the internal or external 10 MHz reference signal. The unit is powered by a 100-240 ±10% VAC, 47-63 Hz input power supply and housed in a 1 3/4" X 19" X 16" rack mount chassis.

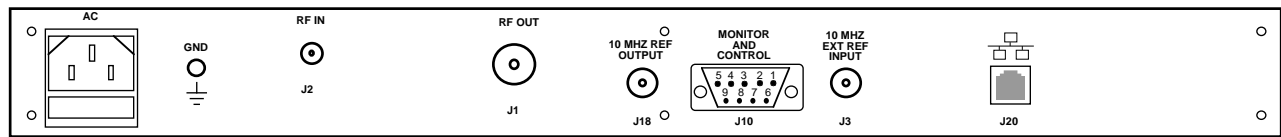
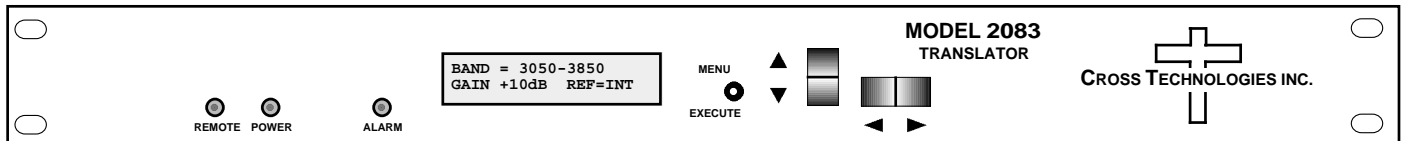

2083-5018# Block Translator front and rear panels (shown with optional Ethernet)

EQUIPMENT SPECIFICATIONS*

Input Characteristics

Input Impedance/RL **50 Ω /14 dB**
 Frequency **2000-5500 MHz**
 Input Level **-20 to -50 dBm**
 Input, max. no damage **+10 dBm**

Output Characteristics

Impedance/RL **50 Ω/14 dB**
 Frequency **950-1750 MHz**
 Output Level **0 to -30 dBm**
 Output 1 dB compression **+10 dBm at max gain**

Channel Characteristics

Gain, max., Range **+30 dB, ± 2 dB, adjustable from 0 to +30 dB in 1 ± 1dB steps**
 Frequency Response **± 1.5 dB, 800 MHz bandwidth; ± 0.5 dB, 36 MHz increment**
 Spurious, Inband, dep. **< -50 dBC (<-55 typical) in band, signal dependent, 950-1750 MHz out, at max gain**
 Spurious, Inband, indep. **< -55 dBC (<-60 typical) in band, signal independent, 950-1750 MHz out, at max gain**
 Group Delay, max. **0.015 ns/MHz², parabolic, 0.03ns/MHz, linear, 1 ns ripple, 36 MHz BW**
 Frequency Sense **Non-inverting**

Synthesizer Characteristics

Frequency Stability **± 0.01 ppm internal reference; external reference input**
 Frequency Step **10 MHz minimum for Fc of 2.4 - 5.1 GHz**
 10 MHz In/Out Level **3 dBm ± 3 dB**

| Phase Noise @ F (Hz) > | 100 | 1K | 10K | 100K | 1M |
|------------------------|-----|-----|-----|------|------|
| dBc/Hz | -60 | -70 | -80 | -90 | -100 |

Controls, Indicators

Input Band frequency **Direct readout LCD; manual or remote selection**
 Gain **Direct readout LCD; manual or remote selection**
 Power; Alarm: Remote **Green LED; Red LED; Yellow LED**
 Remote **RS232C, 9600 baud, W8, W18, W28 Ethernet, optional**

Other

RF In/RF Out Connector **SMA (female) / N (female)**
 10 MHz Connectors **BNC (female), 75Ω, works with 50 or 75 ohms**
 Alarm/Remote Connector **DB9 (female) - NO or NC contact closure on alarm**
 Size **19 inch standard chassis 1.75" High X 16.0" Deep**
 Power **100-240 (±10%) VAC, 47-63 Hz, 30 watts max.**

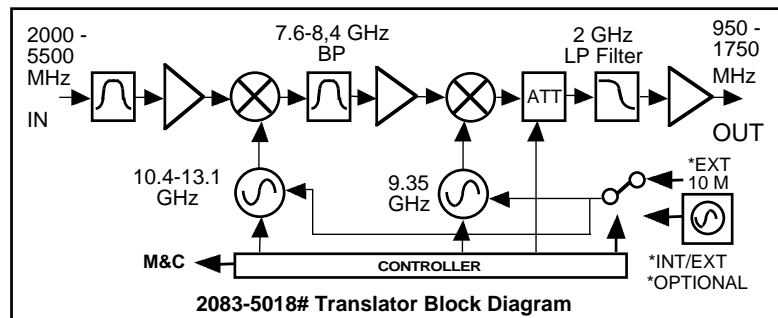

Available Options

- W31 - Ext. Temp 0C to +50C
- Comm. Interface/Standard RS232**
- Q - RS485 Remote Interface
- W8 - Ethernet; w/Web Browser (WB)
- W18 - Ethernet; w/WB & SNMP
- W28 - Ethernet; w/TCP/IP, Telnet

Contact Cross for other options

*+10 to +40 degrees C; Specifications subject to change without notice