

**2016-04A L-band Downconverter**

**2016-04A L-Band Downconverter** - Converts 950 to 2150 MHz to 140 MHz in 1 MHz steps with low group delay and flat frequency response. The 2016-04A Input and Output levels have been optimized to support transmit from an L-band modem to a 140 MHz IF upconverter. Multi-function push button switches select the RF frequency, gain, and other parameters. Front panel LEDs provide indication of DC power (green), PLL alarm (red), and remote operation (yellow). The gain is adjustable from 0 to +50 dB. Remote operation allows selection of frequency and gain. Parameter selection and frequency and gain settings appear on the LCD display. Standard connectors are BNC female for IF output and the optional external reference input and reference output, and Type F female for the RF input. A high stability ( $\pm 0.01$ ppm) reference, LNB +24 VDC, 0.4 Amps power and 10 MHz reference (includes a 10 MHz output connector), are available Options. The unit is powered by a 100-240  $\pm 10\%$  VAC power supply, and housed in a 1.75" X 19" X 16" 1RU chassis

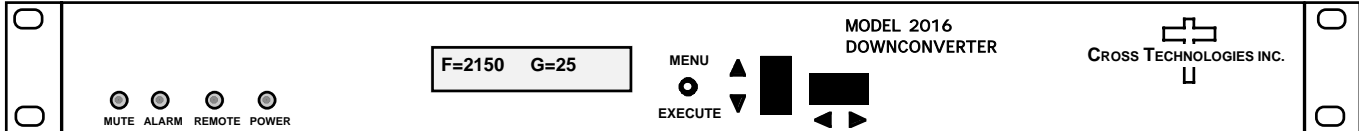

**2016-04A DOWNCONVERTER**

**EQUIPMENT SPECIFICATIONS\***

**Input Characteristics**

Impedance/Return Loss 75 $\Omega$  / 12 dB  
 Frequency 950 to 1525 MHz  
 Noise Figure, Max. 15 dB (max gain)  
 Input Level range -60 to -10 dBm  
 Input 1 dB compression -5 dBm

**Output Characteristics**

Impedance/Return Loss 75 $\Omega$  / 18 dB  
 Frequency 70  $\pm$  18 MHz  
 Output Level/max linear -10 to 0 dBm  
 Output 1 dB compression +5 dBm

**Channel Characteristics**

Gain 0.0 to 50.0 dB, 1 dB steps (manually adjustable)  
 Image Rejection > 50 dB, min  
 Spurious Response <-45 dBC in band ( $\pm 36$  MHz) at -20 dBm out  
 Frequency Response  $\pm 1.5$  dB, 950 -2150 MHz;  $\pm 0.5$  dB, 72 MHz BW  
 Group Delay, max 0.0035 ns/MHz 2 parabolic; 0.025 ns/MHz linear; 1 ns ripple  
 Frequency Sense Non-inverting

**Synthesizer Characteristics**

Frequency Accuracy  $\pm 1.0$  ppm max over temp ( $\pm 0.02$  ppm optional) internal reference; ext. ref. input, optional  
 Frequency Step 1.0 MHz minimum  
 Phase Noise < -70, 0.1, 1 kHz; < -80, 10 kHz; < -90, 100 kHz; < -100, 1 MHz  
 External 10 MHz level 0 dBm,  $\pm 3$  dB, 75 ohms (option -E)

**Controls, Indicators**

Frequency Selection direct readout LCD; pushbutton switches or remote selection  
 Gain Selection direct readout LCD; pushbutton switches or remote selection  
 PWR; Alarm; Rem Green LED; Red LED; Yellow LED  
 Remote RS232C, 9600 baud

**Other**

RF,IF, 10 MHz Connectors Type F, female, BNC, female, BNC, female  
 Connector, Alarm, Remote DB9 - NO or NC contact closure on Alarm  
 Size 19 inch standard chassis 1.75" high X 16.0" deep  
 Power 100 - 240  $\pm 10\%$  VAC, 47 - 63 Hz, 25 watts max.

**MODELS, OPTIONS**

2016-04 950-2150 Input, 140 MHz Output  
 - E Allows external 10 MHz reference input, 10 MHz reference can be inserted on the RF in  
 - L LNB +24 VDC, 0.4 Amps with readout of current  
 - H High Stability ( $\pm 0.02$  ppm) internal reference

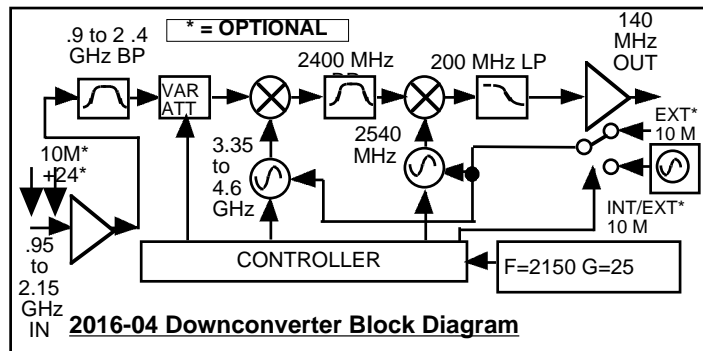

\*+10 to +40 degrees C; Specifications subject to change without notice