

2016-03 L-Band Downconverter

The 2016-03 L-band Downconverter converts 950 to 1525 MHz in 1 MHz steps to 70 ± 18 MHz with low group delay and flat frequency response. Synthesized local oscillators (LO) provide frequency selection. Multi-function push button switches select the RF frequency, gain, and other parameters. Front panel LEDs provide indication of DC power (green), PLL alarm (red), and remote operation (yellow). Gain is adjustable manually over a 0 to +50 dB range as adjusted by the front panel multi-function push-button switches. Remote operation allows selection of frequency and gain. Parameter selection and frequency and gain settings appear on the LCD display. Connectors are BNC female for IF output and the optional external reference input and output, and Type F female for the RF input. LNB +24 VDC, 0.4 Amps and 10 MHz reference can be inserted on the RF line as added options. The 10 MHz option also includes a 10 MHz output connector, which contains either the internal or external 10 MHz reference signal. A high stability (±0.01ppm) option is also available. The unit is powered by a **100-240 ±10% VAC** power supply, and housed in a 1 3/4" X 19" X 16" rack mount chassis.

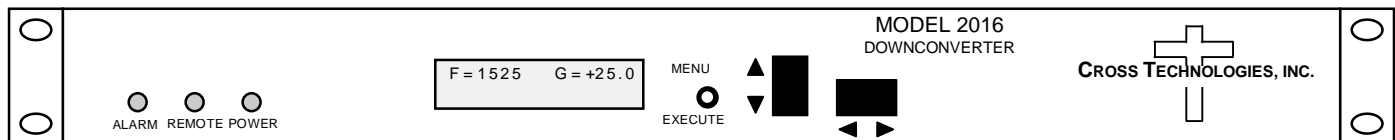

2016-03 Downconverter Front Panel

EQUIPMENT SPECIFICATIONS*

Input Characteristics (RF)

Impedance/Return Loss 75 Ω /12 dB
 Frequency 950 to 1525 MHz
 Noise Figure, max. 15 dB (max gain)
 Input Level Range -20 to -70 dBm
 Input 1dB compression -15 dBm

Output Characteristics (IF)

Impedance/Return Loss 75 Ω/18 dB
 Frequency 70 ± 18 MHz
 Output level/max linear -20dBm / -10dBm
 Output 1 dB comp. -5 dBm

Channel Characteristics

Gain range (adjustable) 0.0 to +50.0 dB
 Image Rejection > 50 dB, min.
 Frequency Response ±1.5 dB, 950 to 1525 MHz ; ± 0.5 dB, 36 MHz BW
 Spurious Response < -50 dBc, in band
 Group Delay, max 0.01 ns/MHz² parabolic; 0.03 ns/MHz linear; 1 ns ripple
 Frequency Sense Inverting or Non-inverting, selectable

Synthesizer Characteristics

Frequency Accuracy ± 1.0 ppm max over temp (±0.01 ppm, option H)
 Frequency Step 1.0 MHz (as low as 1 kHz steps available)

Phase Noise @ Freq	100 Hz	1kHz	10kHz	100kHz	1 MHz
dBC/Hz	-70	-80	-80	-90	-100

10 MHz Level (In or Out) 3 dBm, ± 3 dB, 75 ohms (option E)

Controls, Indicators

Frequency Selection direct readout LCD; manual or remote selection
 Gain Selection direct readout LCD; manual or remote selection
 Power; Alarm; Remote Green LED; Red LED; Yellow LED
 Remote RS232C, 9600 baud (RS485, option Q)

Other

RF Connector Type F (female)
 IF Connector BNC (female)
 10 MHz Connectors BNC (female) (option E)
 Alarm/Remote Connector DB9 (female) - NO or NC contact closure on Alarm
 Size 19 inch, 1RU standard chassis 1.75"high X 16.0" deep
 Power **100-240 ±10% VAC**, 47-63 Hz, 45 watts max

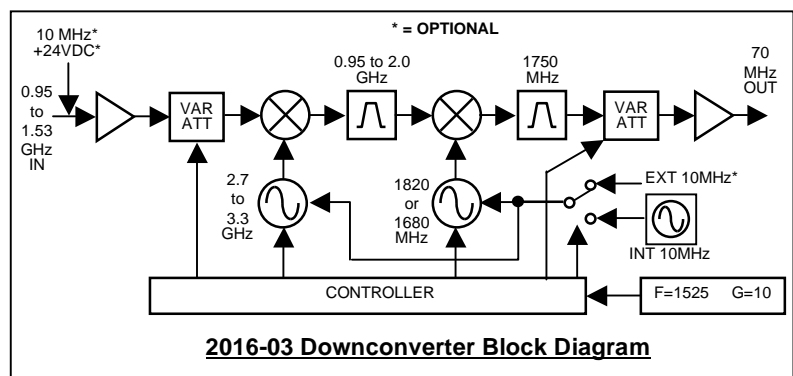

2016-03 Downconverter Block Diagram

Available Options

- E – External 10 MHz ref input & output w/ RF insertion
- H – High Stability (±0.01ppm) internal reference
- L – LNB Voltage, +24VDC, 0.4 amps
- Q – RS485 Remote Interface
- T – Temperature Sensor
- Connectors/Impedance
- B – 75Ω BNC (RF), 75Ω BNC (IF)
- C – 50Ω BNC (RF), 75Ω BNC (IF)
- D – 50Ω BNC (RF), 50Ω BNC (IF)
- N – 50Ω N-type (RF), 75Ω BNC (IF)
- M – 50Ω N-type (RF), 50Ω BNC (IF)

*+10°C to +40°C; Specifications subject to change without notice.

