

2016-03A L-Band Downconverter

The 2016-03A L-band Downconverter converts 950-1525 MHz to 70 (± 18) MHz in 1 MHz steps with low group delay and flat frequency response. The 2016-03A Input and Output levels have been optimized to support transmit from an L-band modem to a 70 MHz IF Upconverter. Multi-function push button switches select the RF frequency, gain, and other parameters. Front panel LEDs provide indication of DC power (green), PLL alarm (red), and remote operation (yellow). The gain is adjustable from 0 to +50 dB. Remote operation allows selection of frequency and gain. Parameter selection and frequency and gain settings appear on the LCD display. Standard connectors are BNC female for IF output and the optional external reference input and reference output, and Type F female for the RF input. LNB +24 VDC, 0.4 Amps and 10 MHz reference can be inserted on the RF line as added options. The 10 MHz option also includes a 10 MHz output connector, which contains either the internal or external 10 MHz reference signal. A high stability (± 0.01 ppm) option is also available. The unit is powered by a 100-240 $\pm 10\%$ VAC power supply, and housed in a 1.75" X 19" X 16" 1RU chassis.

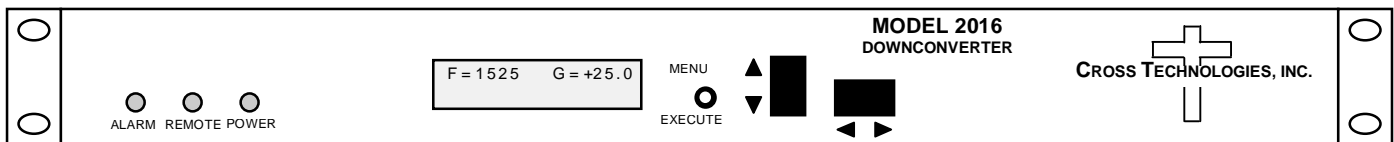

2016-03A Downconverter Front Panel

EQUIPMENT SPECIFICATIONS*

Input Characteristics (RF)

Impedance/Return Loss 75 Ω /12 dB
 Frequency 950 to 1525 MHz
 Noise Figure, max. 15 dB (max gain)
 Input Level Range **-60 to -10 dBm**
 Input 1dB compression **-5 dBm**

Output Characteristics (IF)

Impedance/Return Loss 75 Ω /18 dB
 Frequency 70 \pm 18 MHz
 Output level **-10 to 0 dBm**
 Output 1 dB comp. **+5 dBm**

Channel Characteristics

Gain range (adjustable) 0 to +50 dB
 Image Rejection > 50 dB, min.
 Frequency Response ± 1.5 dB, 950 to 1525 MHz; ± 0.5 dB, 36 MHz BW
 Spurious Response < -50 dBc, in band, f > 970 MHz
 Group Delay, max .01 ns/MHz² parabolic; .03 ns/MHz linear; 1 ns ripple
 Freq Sense (selectable) Inverting or Non-inverting (selectable)

Synthesizer Characteristics

Frequency Accuracy ± 1.0 ppm max over temp (± 0.01 ppm, option H)
 Frequency Step 1.0 MHz (as low as 1 kHz steps available)

Phase Noise @ Freq	100 Hz	1kHz	10kHz	100kHz	1 MHz
dBc/Hz	-70	-70	-80	-90	-100

10 MHz Level (In or Out) 3 dBm, ± 3 dB, 75 ohms (option E)

Controls, Indicators

Frequency Selection direct readout LCD; manual or remote selection
 Gain Selection direct readout LCD; manual or remote selection
 Power; Alarm; Remote Green LED; Red LED; Yellow LED
 Remote RS232C, 9600 baud (RS485, option Q)

Other

RF Connector Type F (female)
 IF Connector BNC (female)
 10 MHz Connectors BNC (female) (option E)
 Alarm/Remote Connector DB9 (female) - NO or NC contact closure on Alarm
 Size 19 inch, 1RU standard chassis 1.75"high X 16.0" deep
 Power 100-240 $\pm 10\%$ VAC, 47-63 Hz, 25 watts max

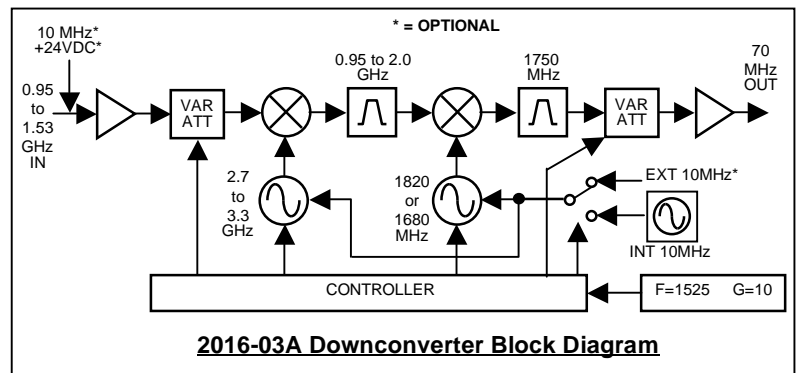

2016-03A Downconverter Block Diagram

Available Options

E – External 10 MHz ref input & output w/ RF insertion
 H – High Stability (± 0.01 ppm) internal reference
 L – LNB Voltage, +24VDC, 0.4 amps
 Q – RS485 Remote Interface
 T – Temperature Sensor
 Connectors/Impedance
 B – 75 Ω BNC (RF), 75 Ω BNC (IF)
 C – 50 Ω BNC (RF), 75 Ω BNC (IF)
 D – 50 Ω BNC (RF), 50 Ω BNC (IF)
 N – 50 Ω N-type (RF), 75 Ω BNC (IF)
 M – 50 Ω N-type (RF), 50 Ω BNC (IF)

*+10°C to +40°C; Specifications subject to change without notice.