

1582-650 RF SWITCH

Provides Auto, Manual or Remote relay switching between CH1 and CH2 RF signals. Alarm conditions on CH1 and CH2 are either a contact closure to ground or an open (selectable). The logic controls one single pole, double throw RF switch. Switching logic can be selected as follows:

1) CH1 Prime Mode - Switches from CH1 to the CH2 only if CH1 alarms and CH2 is good. Switches back when CH1 no longer in alarm or both CH1 and CH2 are bad.

2) Latch to CH2 Mode - Switches to CH2 if CH1 alarms and CH2 is good. Latches to CH2. Push Manual Reset or ground Remote Reset pin to return to CH1 if it has no alarm.

3) Minimum AUTO switching, Initial Channel Select (ICS) Mode - Switch stays on channel last selected by Manual or Remote selection after return to AUTO. AUTO switching occurs only if current channel alarms and other channel clear.

When power is lost, channel one is selected. The Manual Select switch and (when in AUTO) contact closures to Remote Select pins, select CH1 or CH2 independent of alarms. LEDs indicate alarm and switch conditions for CH1 and CH2 and REMOTE or MANUAL operation. Redundant power supplies provided.

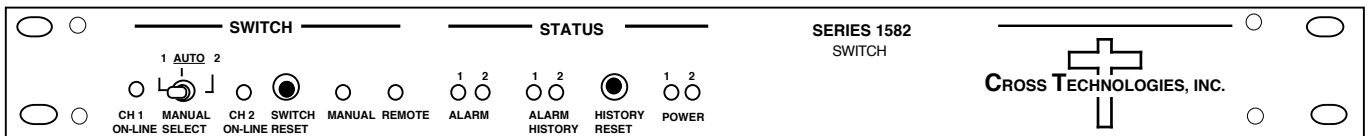

1582-650 RF Switch

1582-650 Technical Specifications

Switch Characteristics

Impedance	50 ohms, Type N
Return Loss	>18 dB DC to 4 GHz >15 dB to 6.5 GHz;
Type	Relay
Isolation	>70 dB DC to 4 GHz >60 dB to 6.5 GHz;
Switch time	≤10 milliseconds
Insertion Loss	≤1 dB to 4.0 GHz; ≤1.5 dB to 6.5 GHz
Configuration	SPDT, no termination

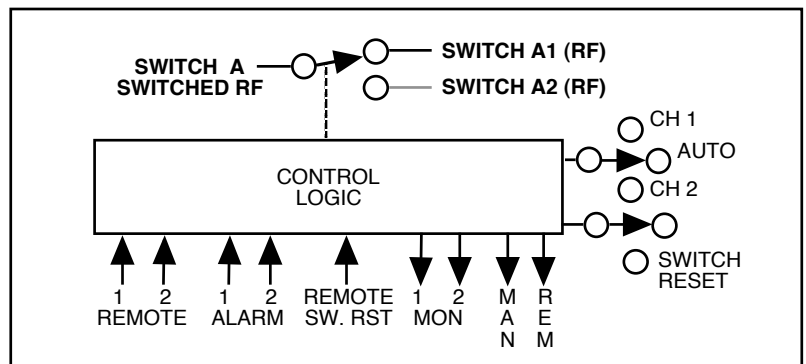

1582-650 Switch Block Diagram

Controls and Indicators

Manual Select	Manually select CH1, CH2
SWITCH RESET	Resets to CH1 in latch mode, Also Resets REMOTE
HISTORY RESET	Resets alarm history (prior occurrence of alarms now cleared) LEDs only
LEDS (*= Closures)	CH1*, CH2* ON-LINE, ALARM, ALARM HISTORY, POWER; MANUAL*; REMOTE*

Other

Connectors	Terminal Strip (alarms and controls)
Connectors	RF, 50 ohm N, female, (Option-S , SMA Connectors)
Mechanical	19 inch standard chassis 1.75" high X 12" deep
Power	Redundant power supplies; 100-240 ± 10% VAC, 47 -63 Hz, 30 watts

*+10 to +40 degrees C; 2000 meters max elevation; 80% max humidity; Specifications subject to change without notice